

**2000 System Wiring Diagrams**

**Pontiac - Sunfire**

**AIR CONDITIONING**

# 2000 Pontiac Sunfire SE

## 2000 System Wiring Diagrams 'Pontiac - Sunfire

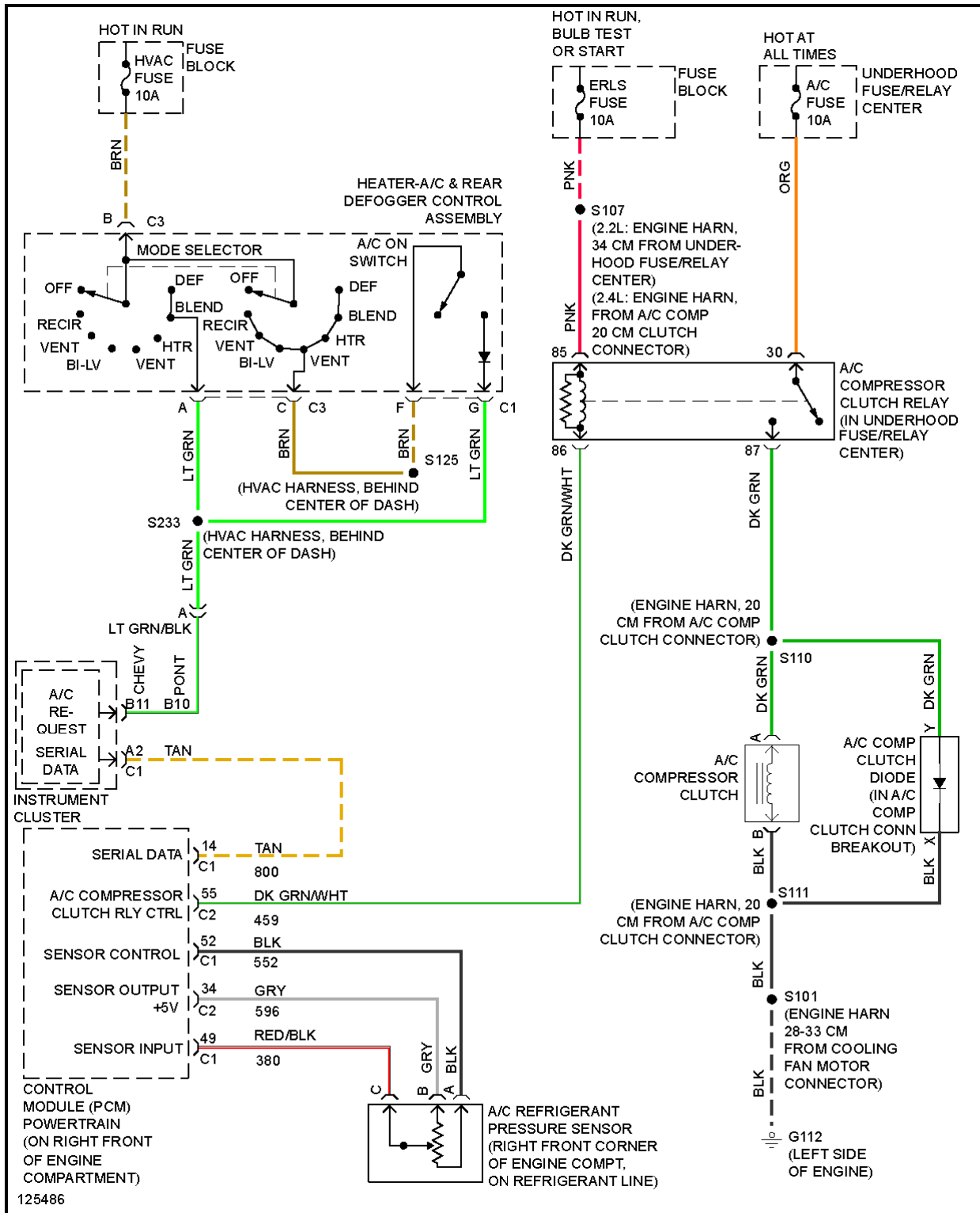

**Fig. 1: Compressor Circuit**

# 2000 Pontiac Sunfire SE

## 2000 System Wiring Diagrams 'Pontiac - Sunfire

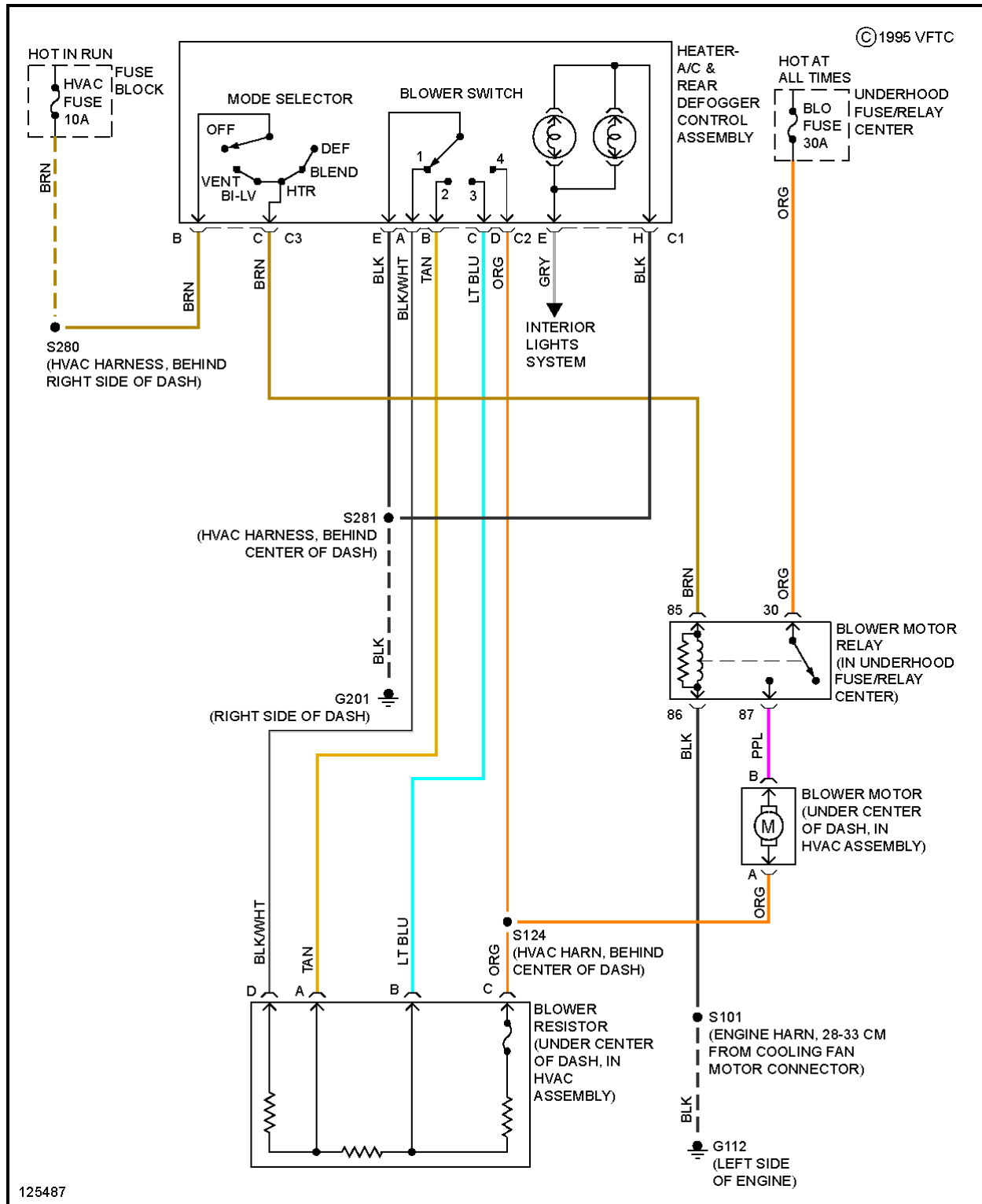

**Fig. 2: Heater Circuit**

# 2000 Pontiac Sunfire SE

## 2000 System Wiring Diagrams 'Pontiac - Sunfire

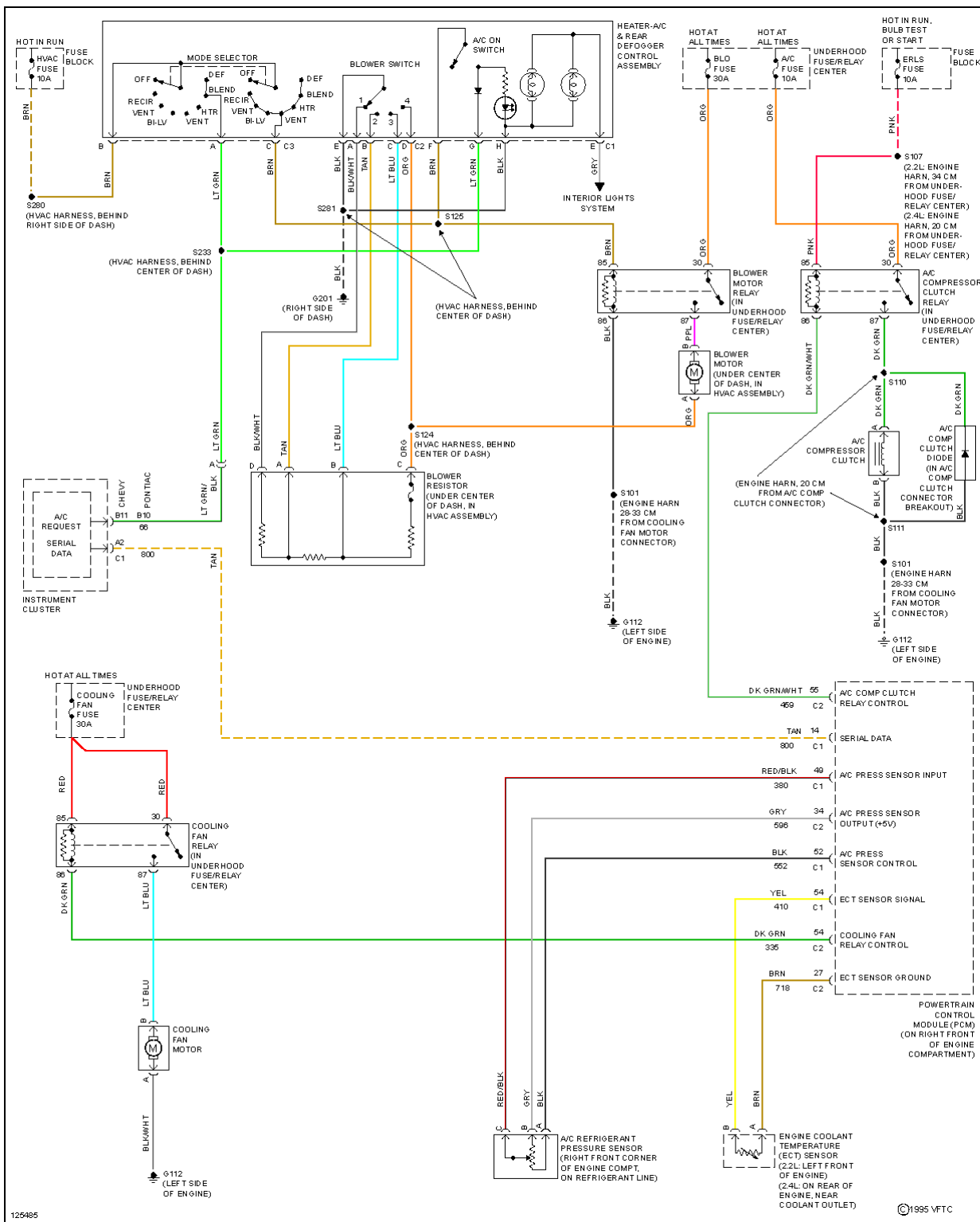
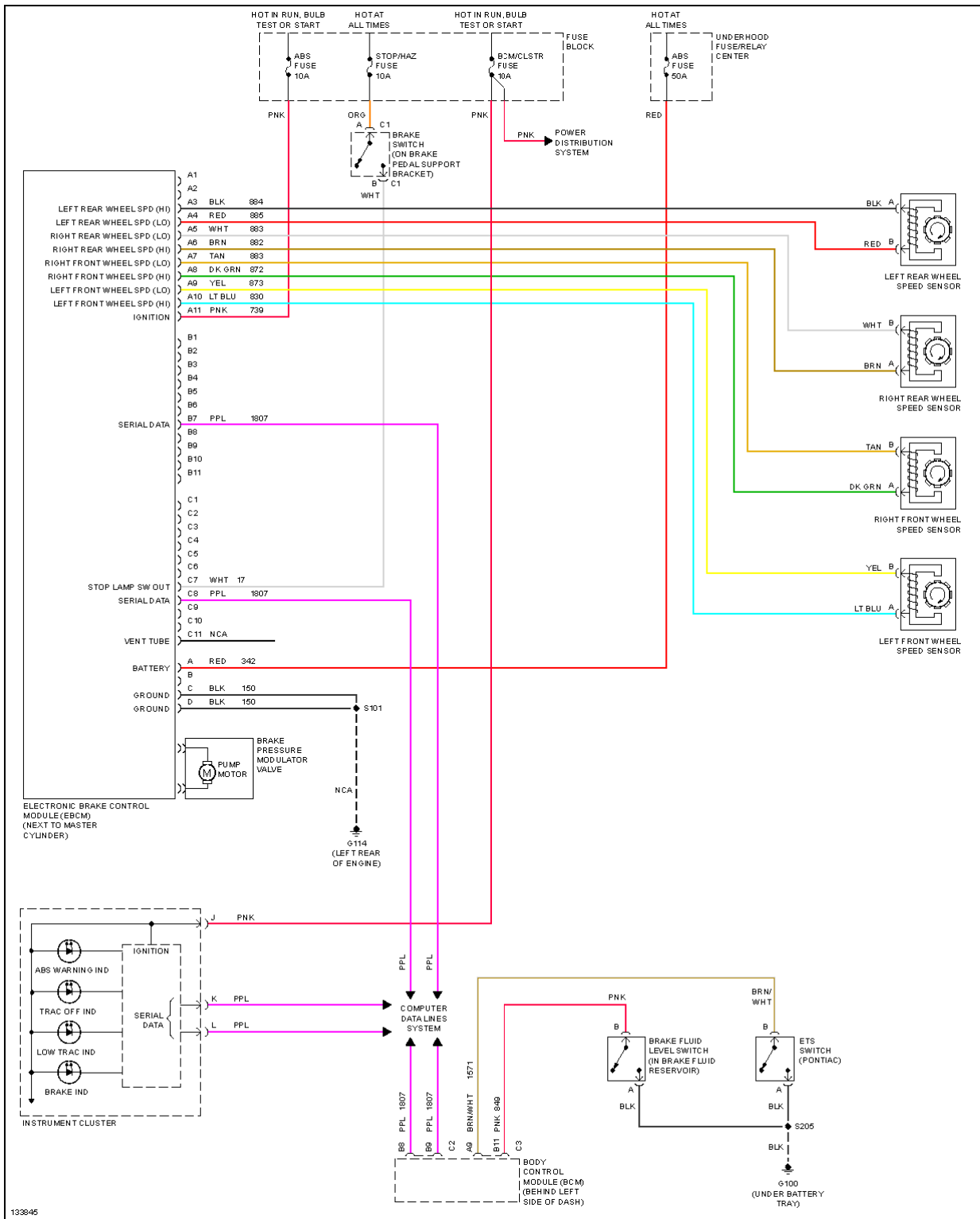

**Fig. 3: Manual A/C Circuit**

## ANTI-LOCK BRAKES

# 2000 Pontiac Sunfire SE

## 2000 System Wiring Diagrams 'Pontiac - Sunfire



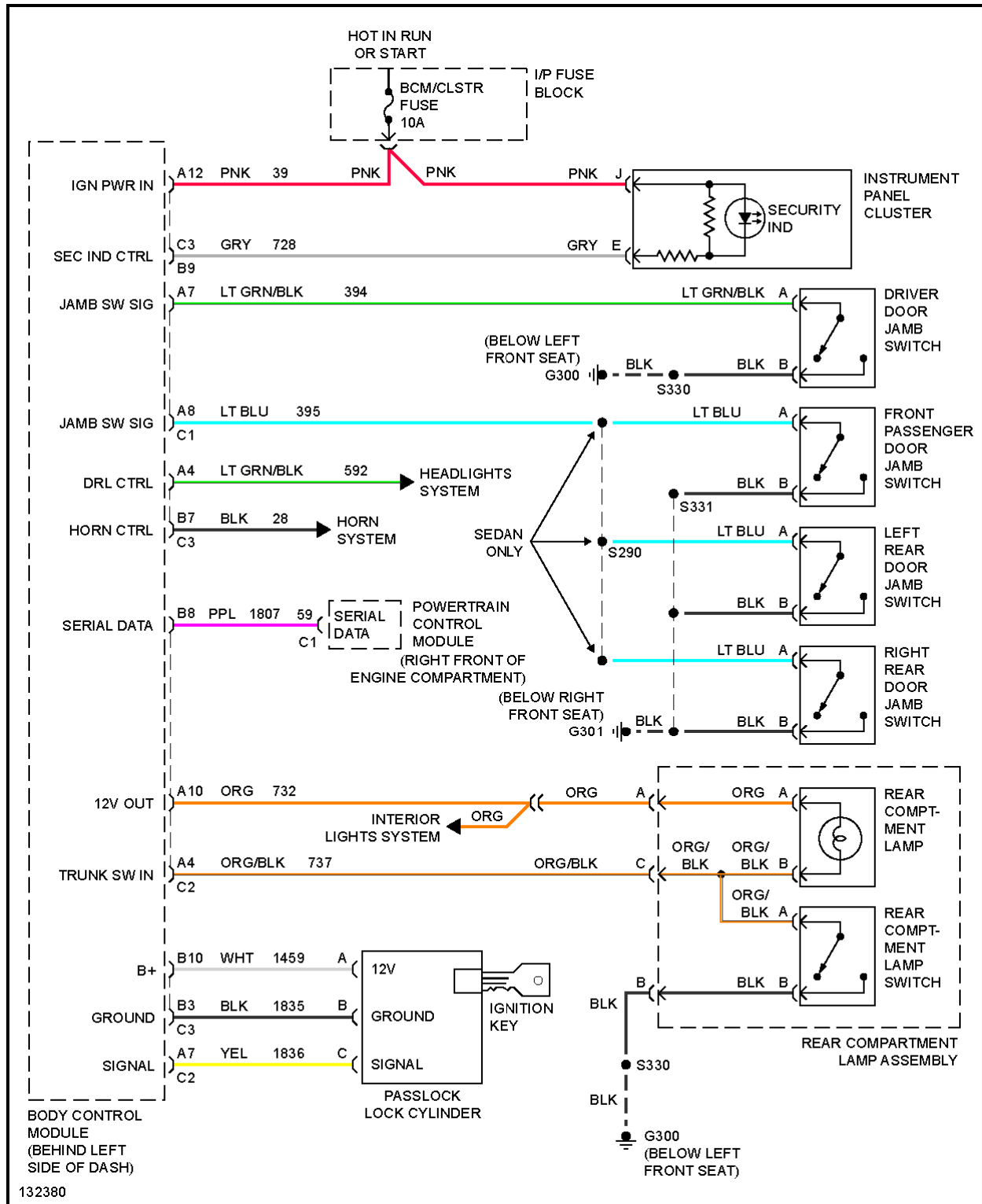

**Fig. 4: Anti-lock Brake Circuits**

**ANTI-THEFT**

# 2000 Pontiac Sunfire SE

## 2000 System Wiring Diagrams 'Pontiac - Sunfire

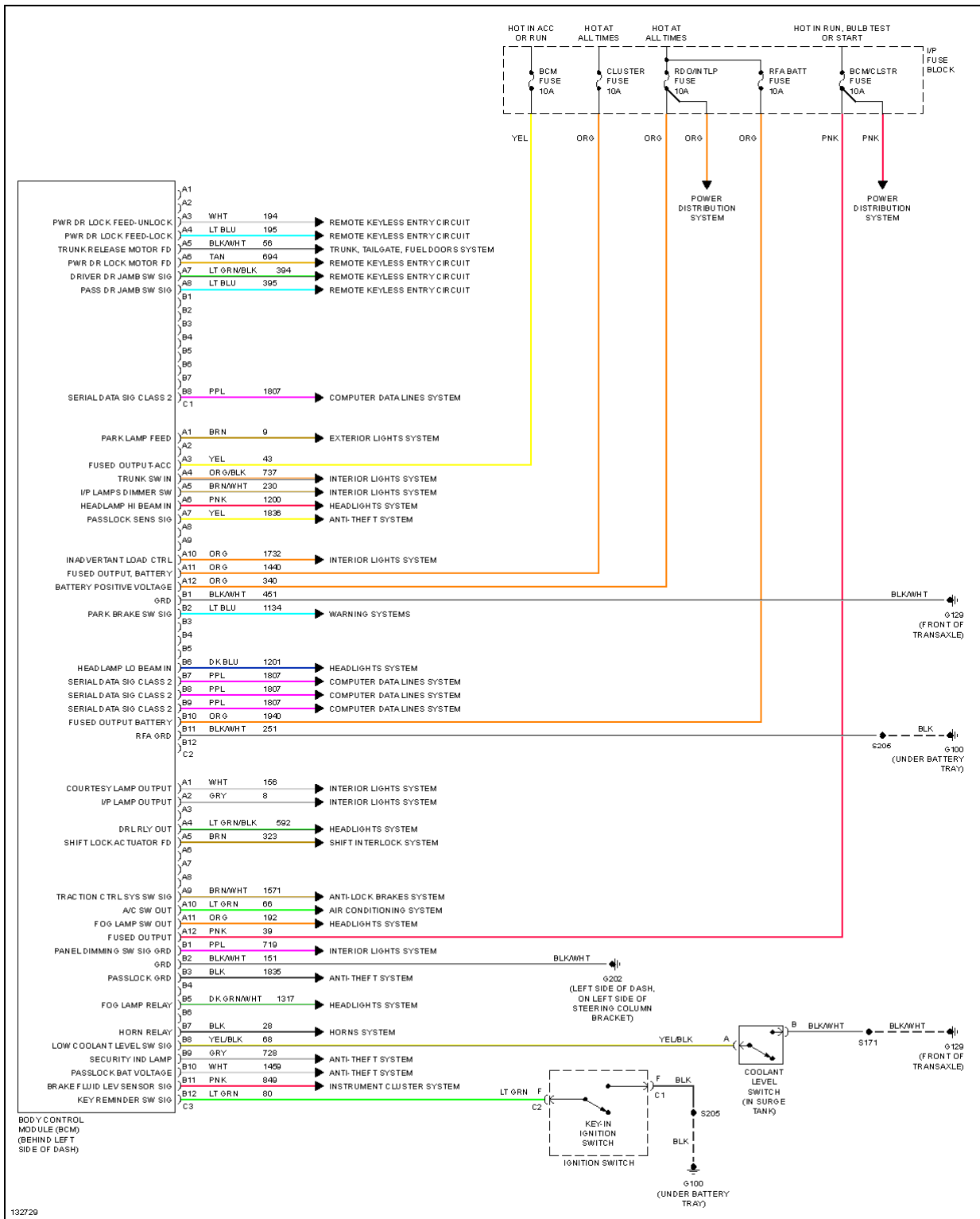

**Fig. 5: Anti-theft Circuit**

**BODY COMPUTER**

# 2000 Pontiac Sunfire SE

## 2000 System Wiring Diagrams 'Pontiac - Sunfire

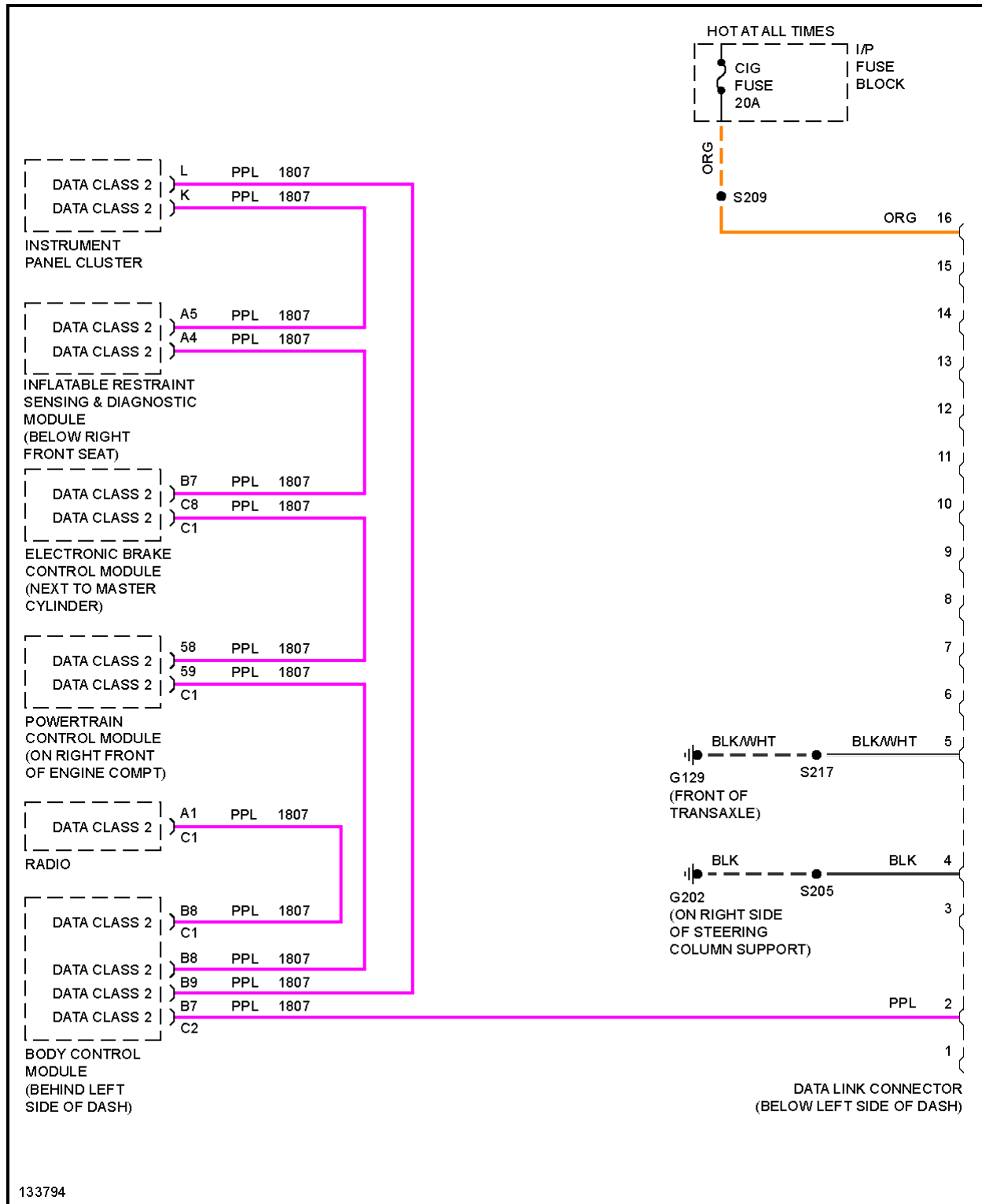

**Fig. 6: Body Computer Circuits**

## COMPUTER DATA LINES

# 2000 Pontiac Sunfire SE

## 2000 System Wiring Diagrams 'Pontiac - Sunfire

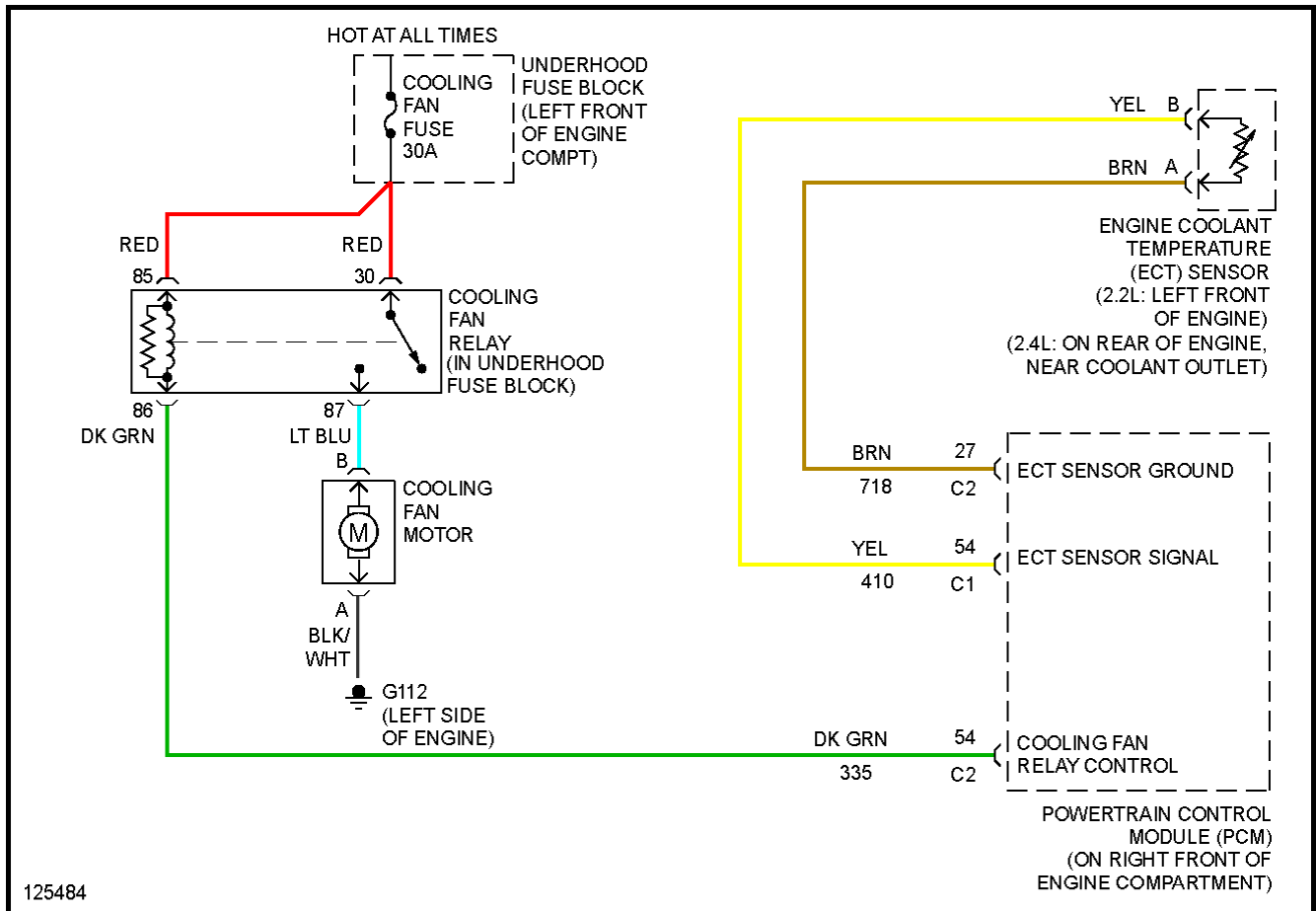

**Fig. 7: Computer Data Lines**

**COOLING FAN**

# 2000 Pontiac Sunfire SE

## 2000 System Wiring Diagrams' 'Pontiac - Sunfire



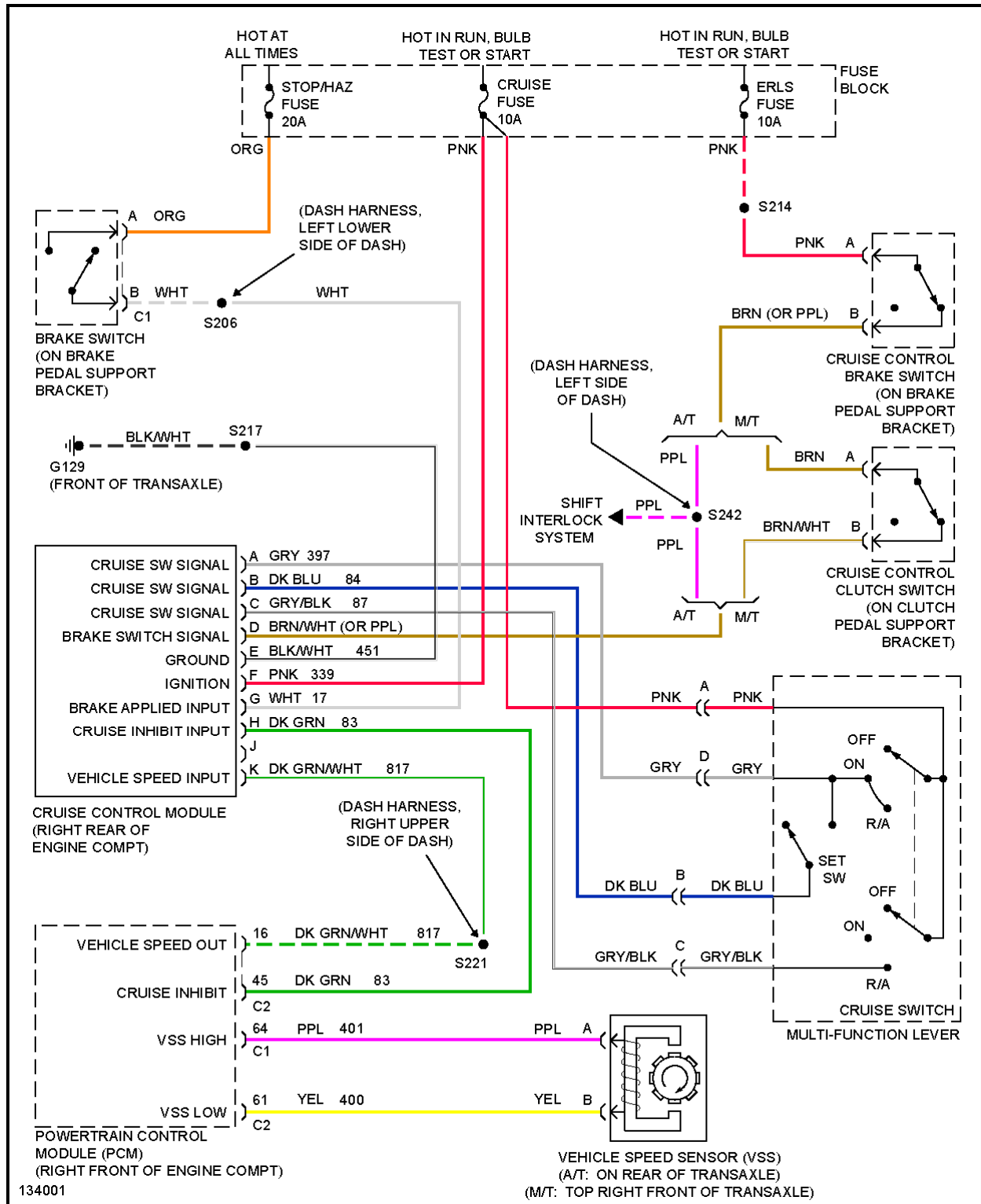

**Fig. 8: Cooling Fan Circuit**

**CRUISE CONTROL**

# 2000 Pontiac Sunfire SE

## 2000 System Wiring Diagrams 'Pontiac - Sunfire



134001

**Fig. 9: Cruise Control Circuit**

**DEFOGGERS**

# 2000 Pontiac Sunfire SE

## 2000 System Wiring Diagrams 'Pontiac - Sunfire

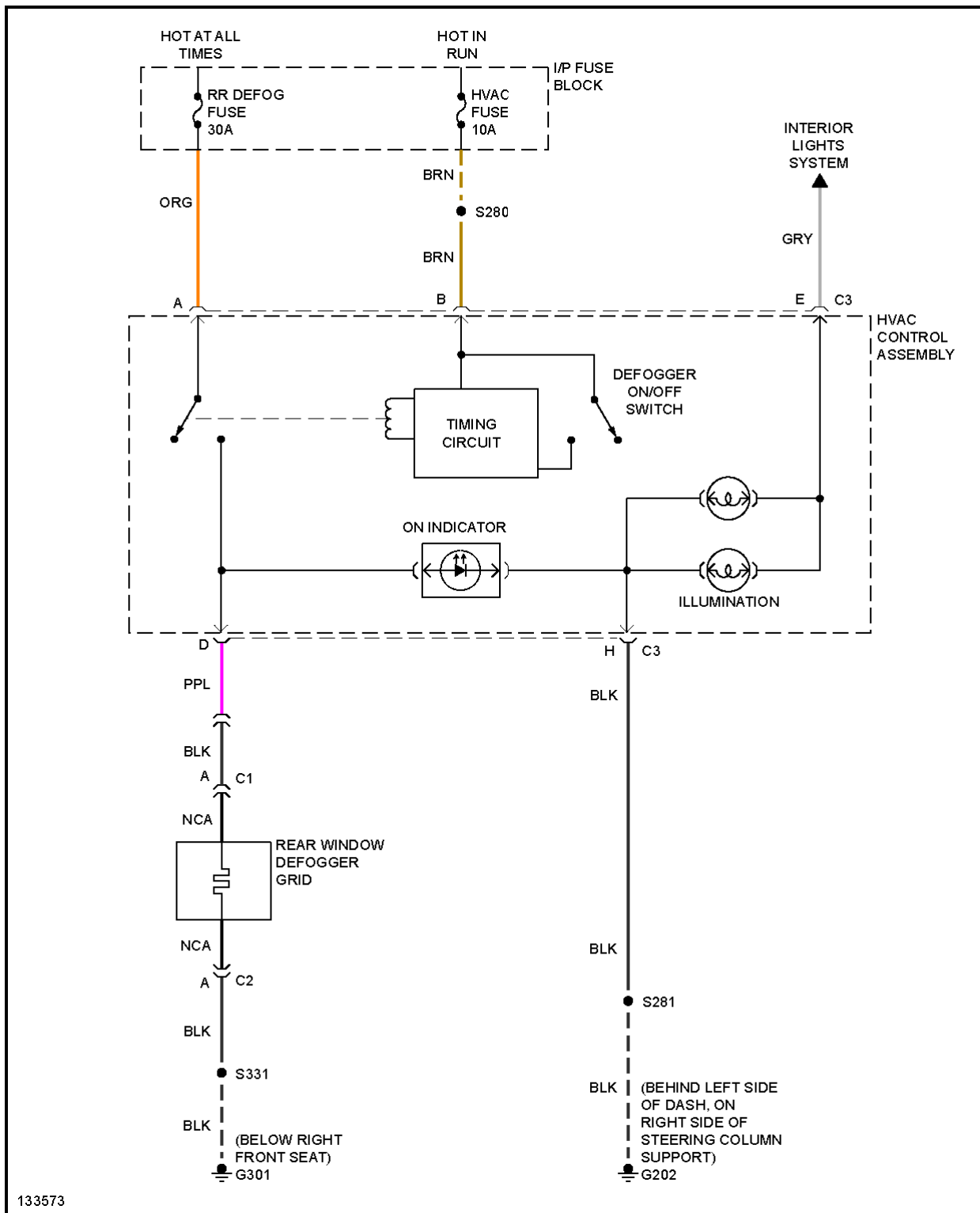

**Fig. 10: Defogger Circuit**

**ENGINE PERFORMANCE**

2.2L

# 2000 Pontiac Sunfire SE

## 2000 System Wiring Diagrams 'Pontiac - Sunfire

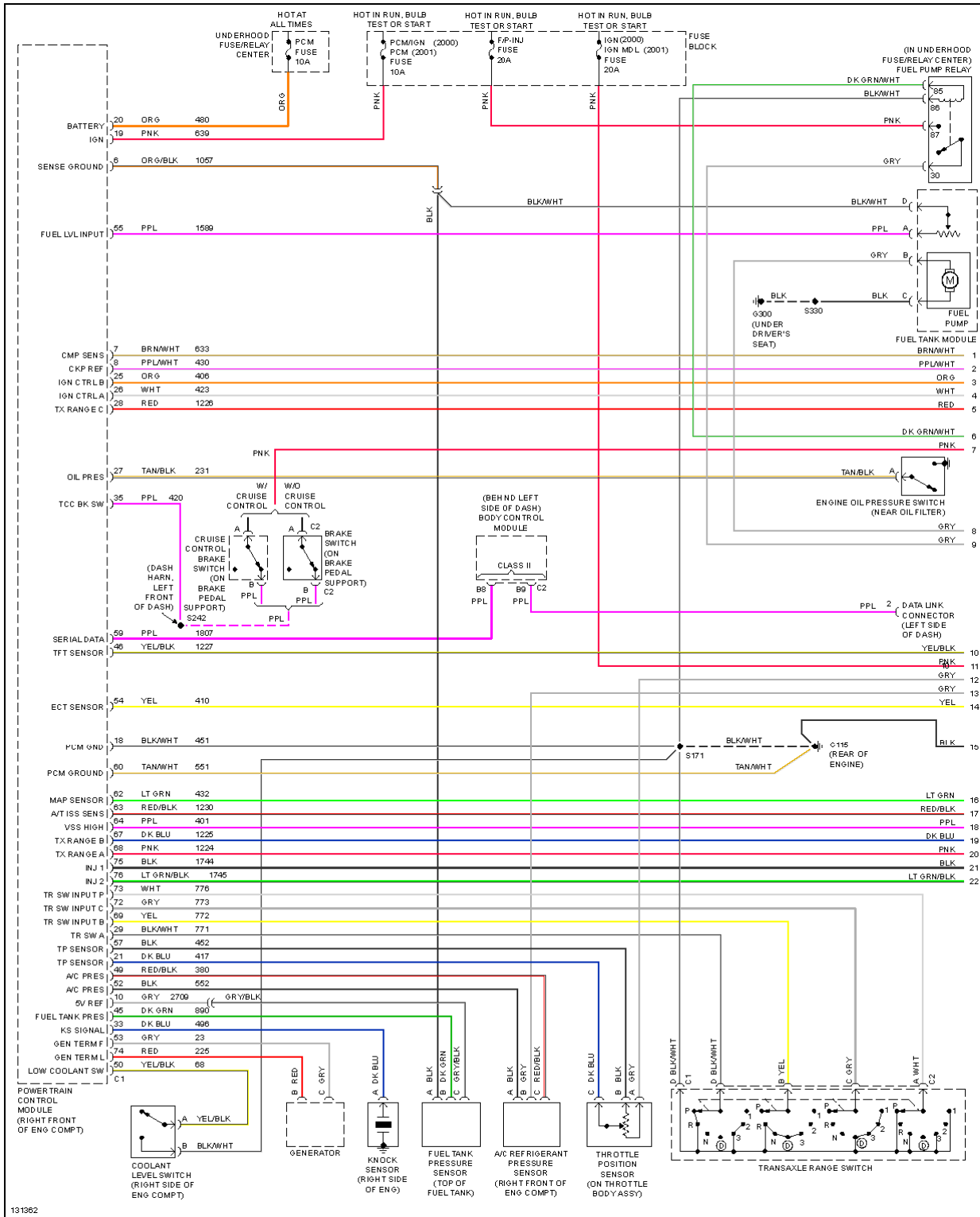

131362

**Fig. 11: 2.2L VIN 4, Engine Performance Circuits (1 of 3)**

# 2000 Pontiac Sunfire SE

## 2000 System Wiring Diagrams 'Pontiac - Sunfire

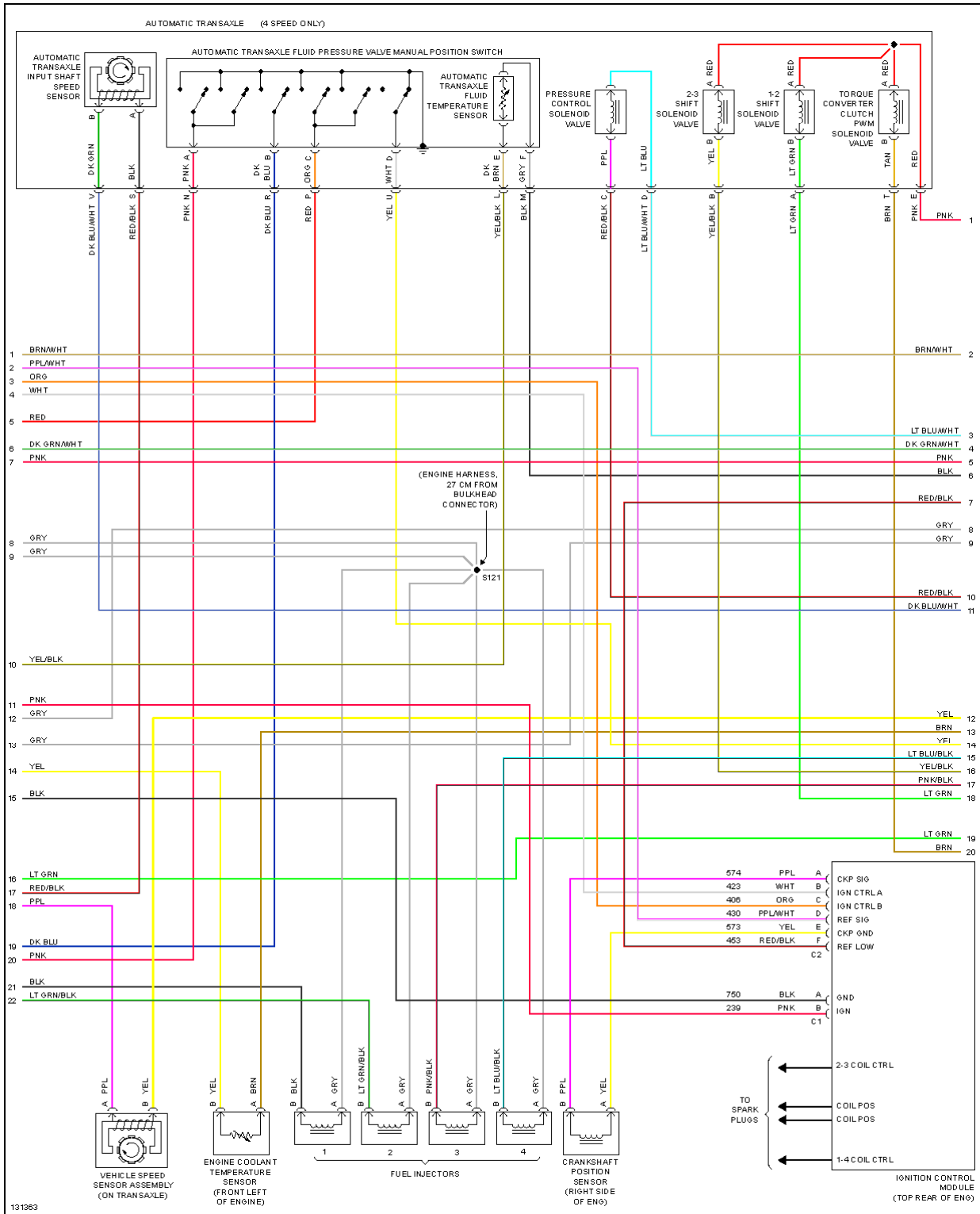
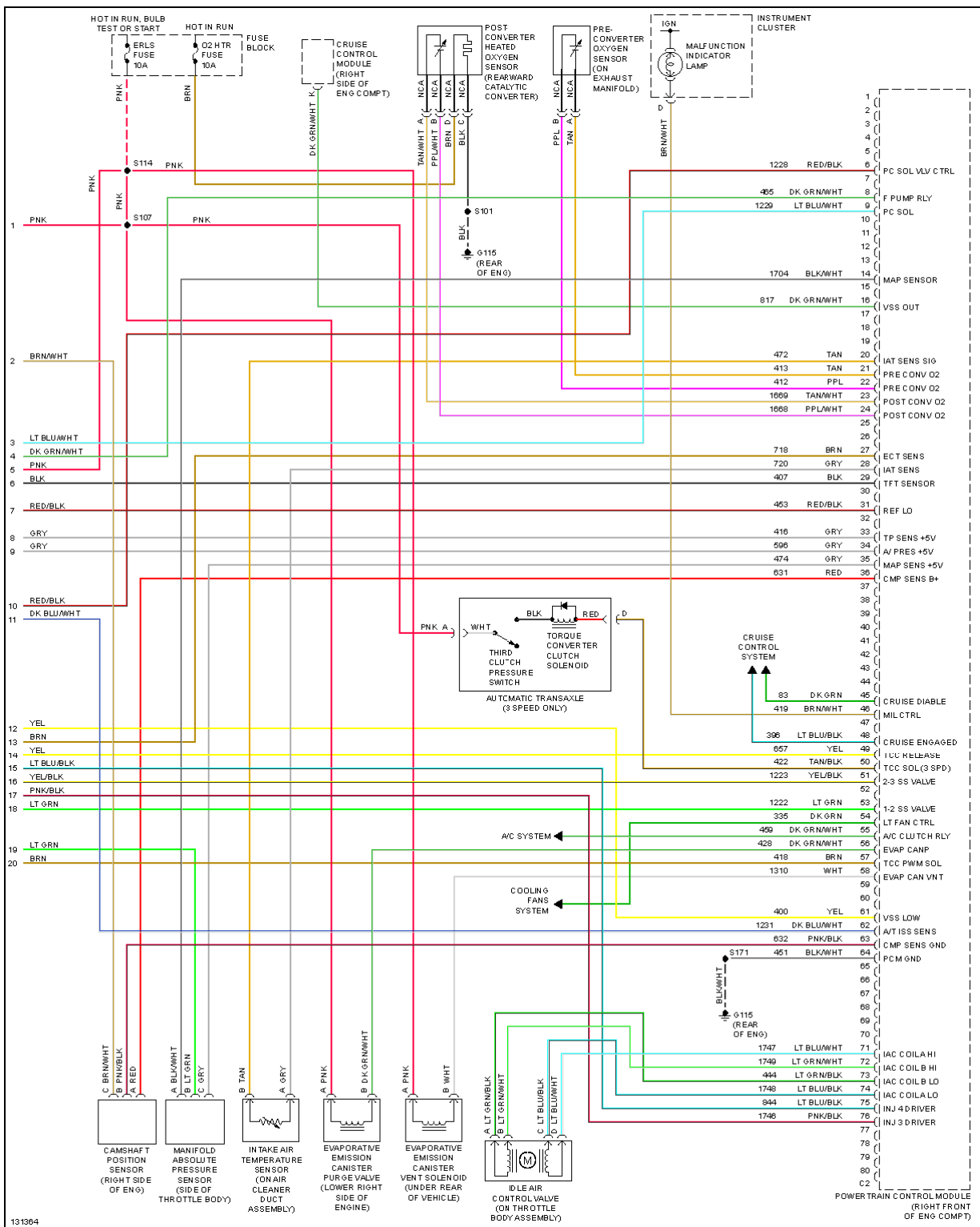



**Fig. 12: 2.2L VIN 4, Engine Performance Circuits (2 of 3)**

# 2000 Pontiac Sunfire SE

## 2000 System Wiring Diagrams 'Pontiac - Sunfire

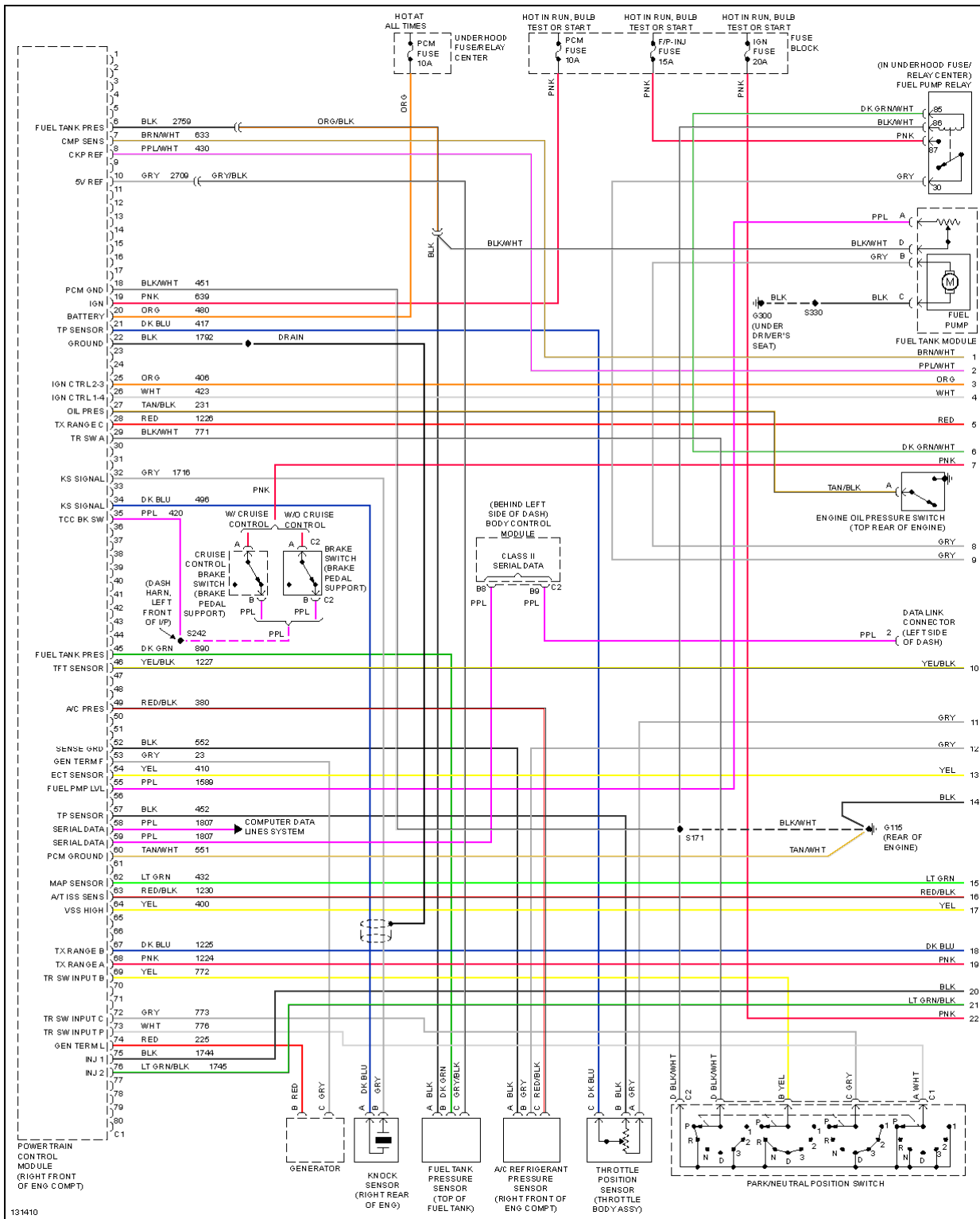

**Fig. 13: 2.2L VIN 4, Engine Performance Circuits (3 of 3)**

**2.4L**

# 2000 Pontiac Sunfire SE

## 2000 System Wiring Diagrams 'Pontiac - Sunfire



131410

**Fig. 14: 2.4L VIN T, Engine Performance Circuits (1 of 3)**

# 2000 Pontiac Sunfire SE

## 2000 System Wiring Diagrams 'Pontiac - Sunfire

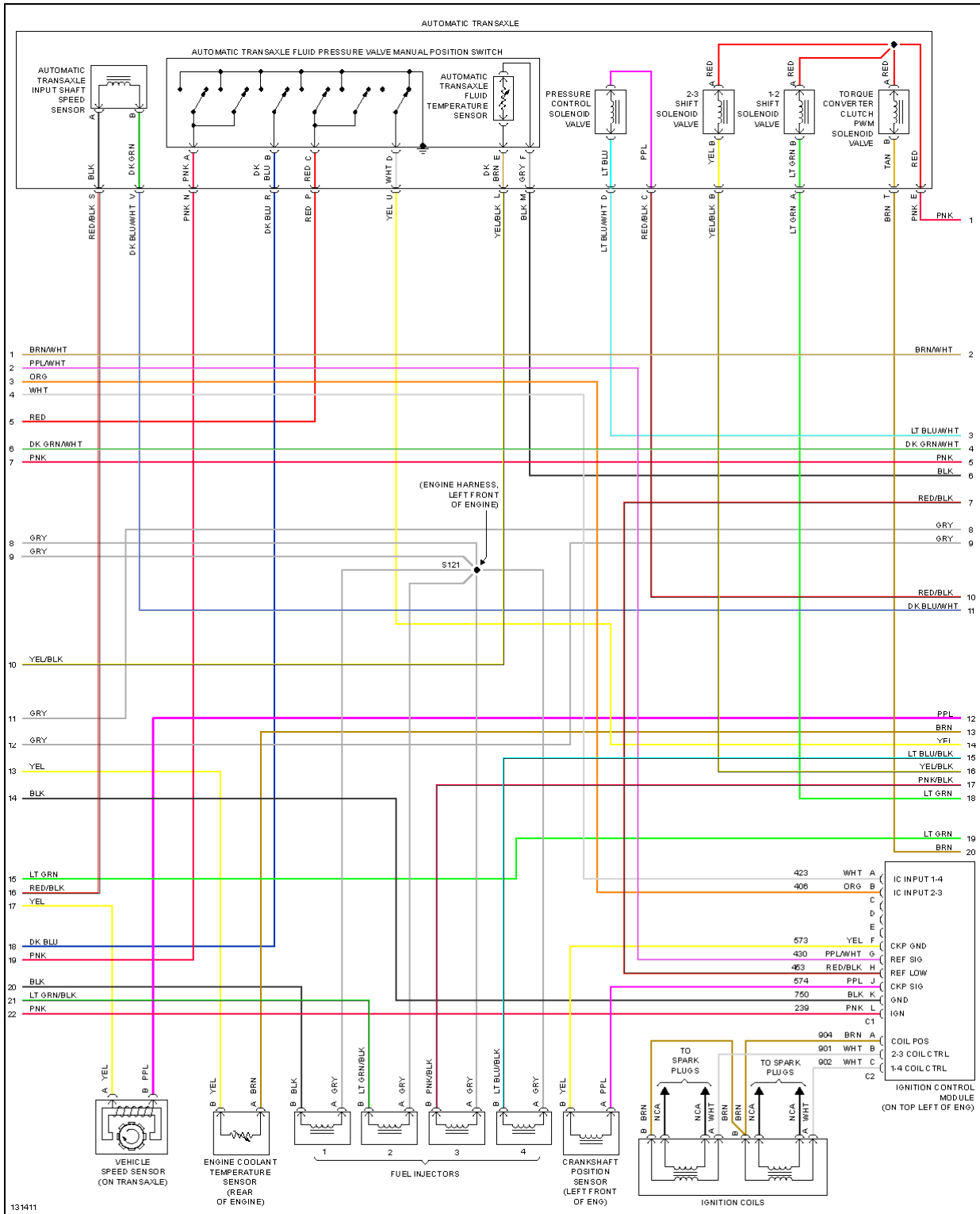

**Fig. 15: 2.4L VIN T, Engine Performance Circuits (2 of 3)**

# 2000 Pontiac Sunfire SE

## 2000 System Wiring Diagrams 'Pontiac - Sunfire

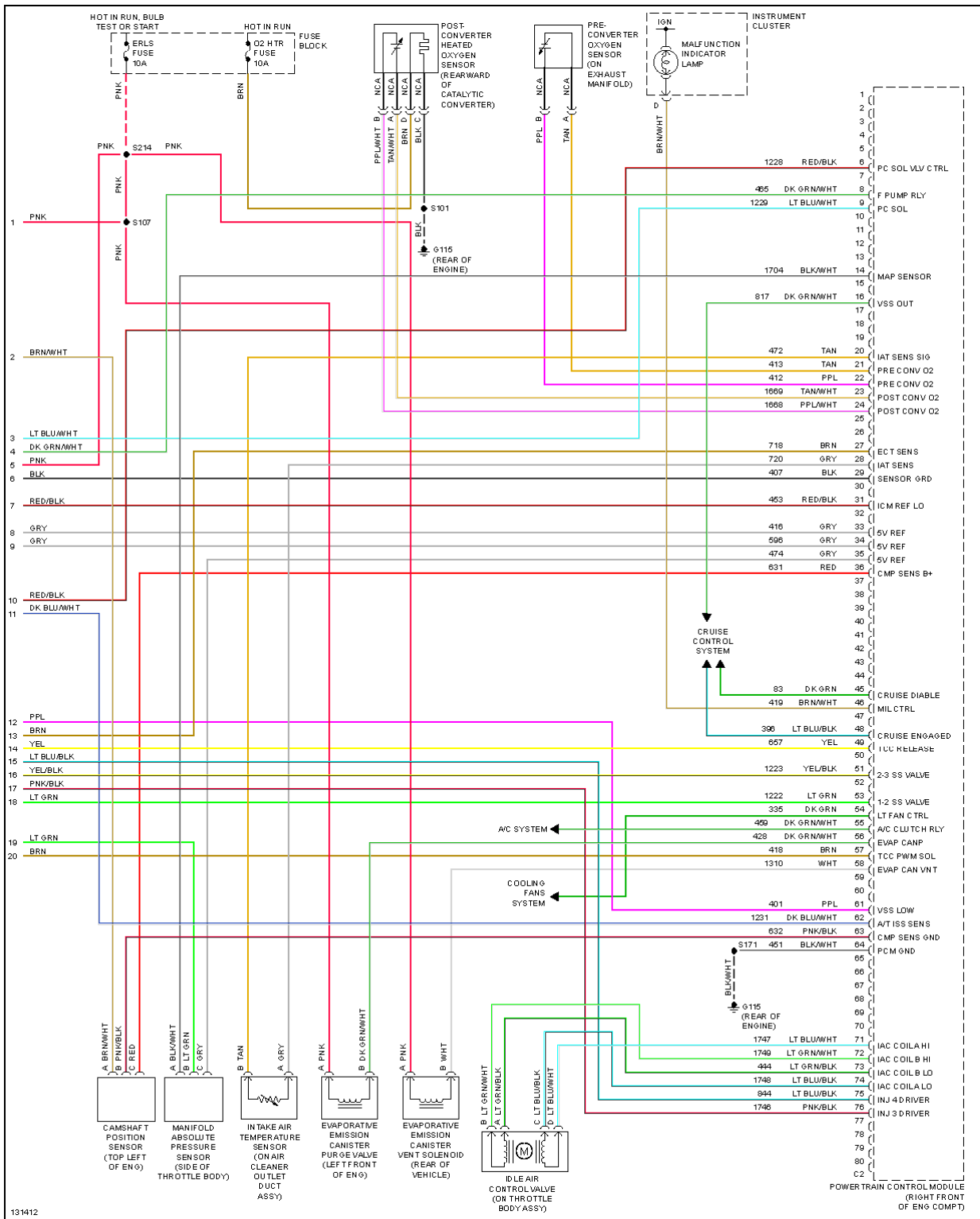

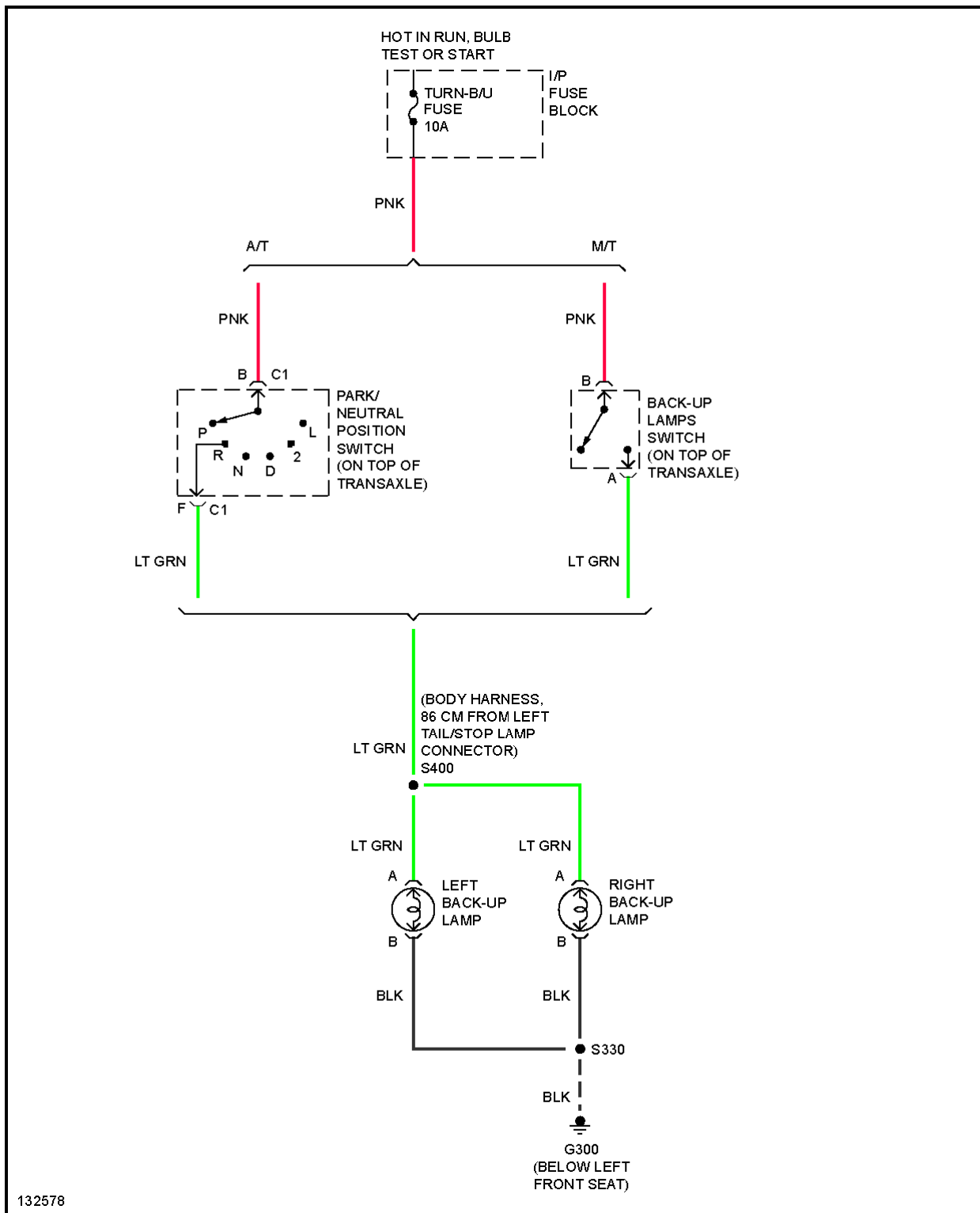

**Fig. 16: 2.4L VIN T, Engine Performance Circuits (3 of 3)**

## EXTERIOR LIGHTS

# 2000 Pontiac Sunfire SE

## 2000 System Wiring Diagrams 'Pontiac - Sunfire



**Fig. 17: Backup Lamps Circuit**

# 2000 Pontiac Sunfire SE

## 2000 System Wiring Diagrams 'Pontiac - Sunfire

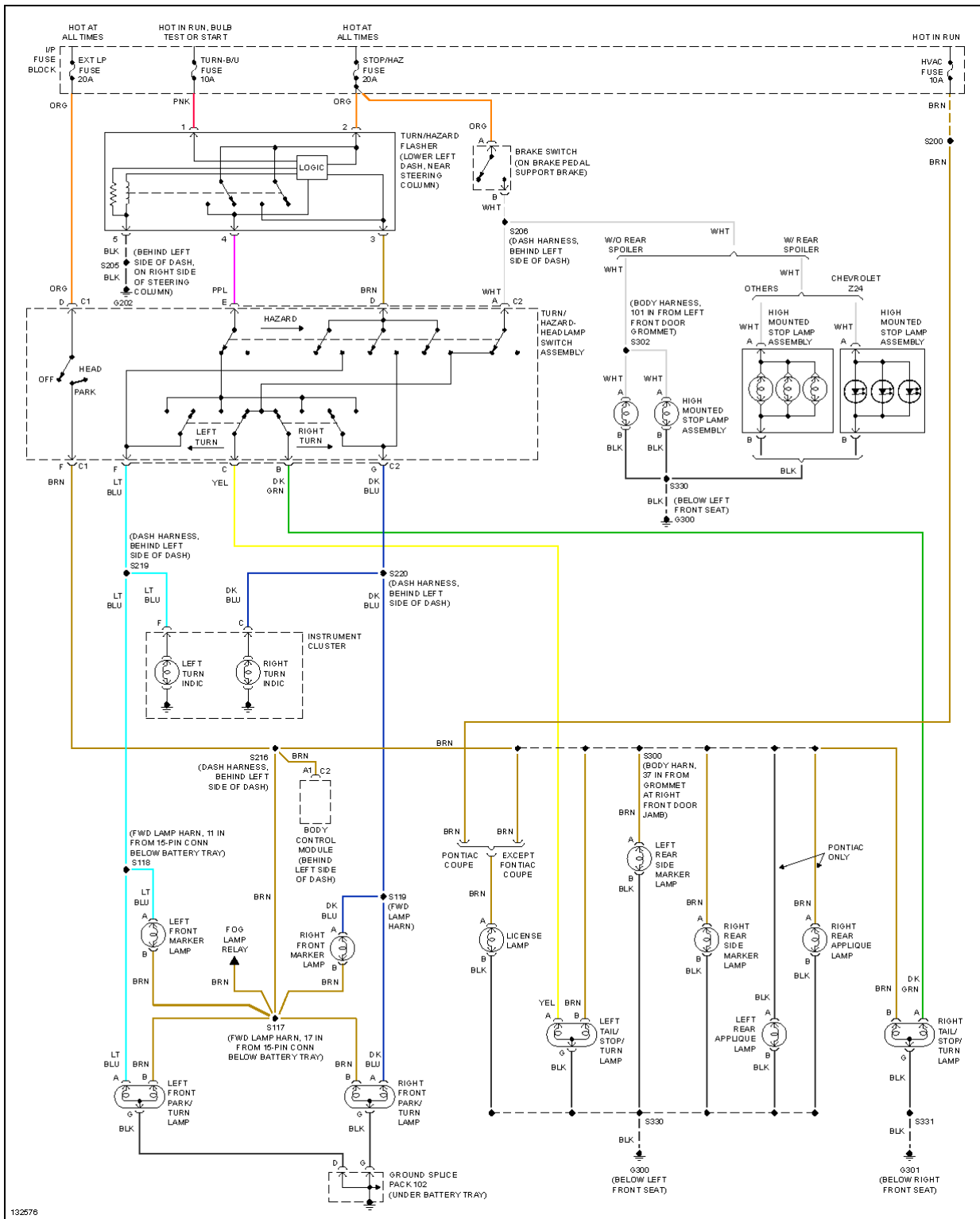

132576

**Fig. 18: Exterior Lamps Circuit**

**GROUND DISTRIBUTION**

# 2000 Pontiac Sunfire SE

## 2000 System Wiring Diagrams 'Pontiac - Sunfire

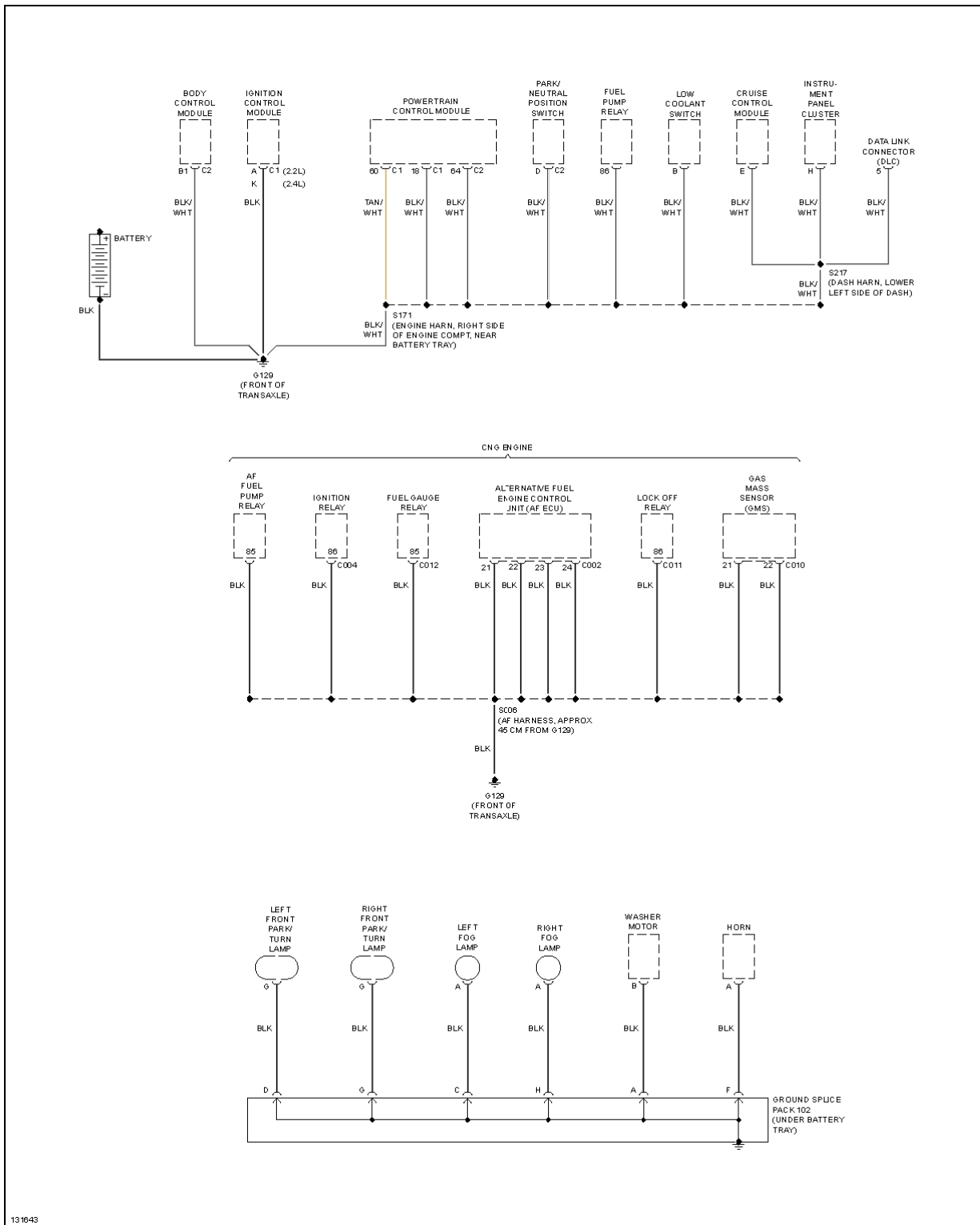

131643

**Fig. 19: Ground Distribution Circuit (1 of 3)**

# 2000 Pontiac Sunfire SE

## 2000 System Wiring Diagrams 'Pontiac - Sunfire

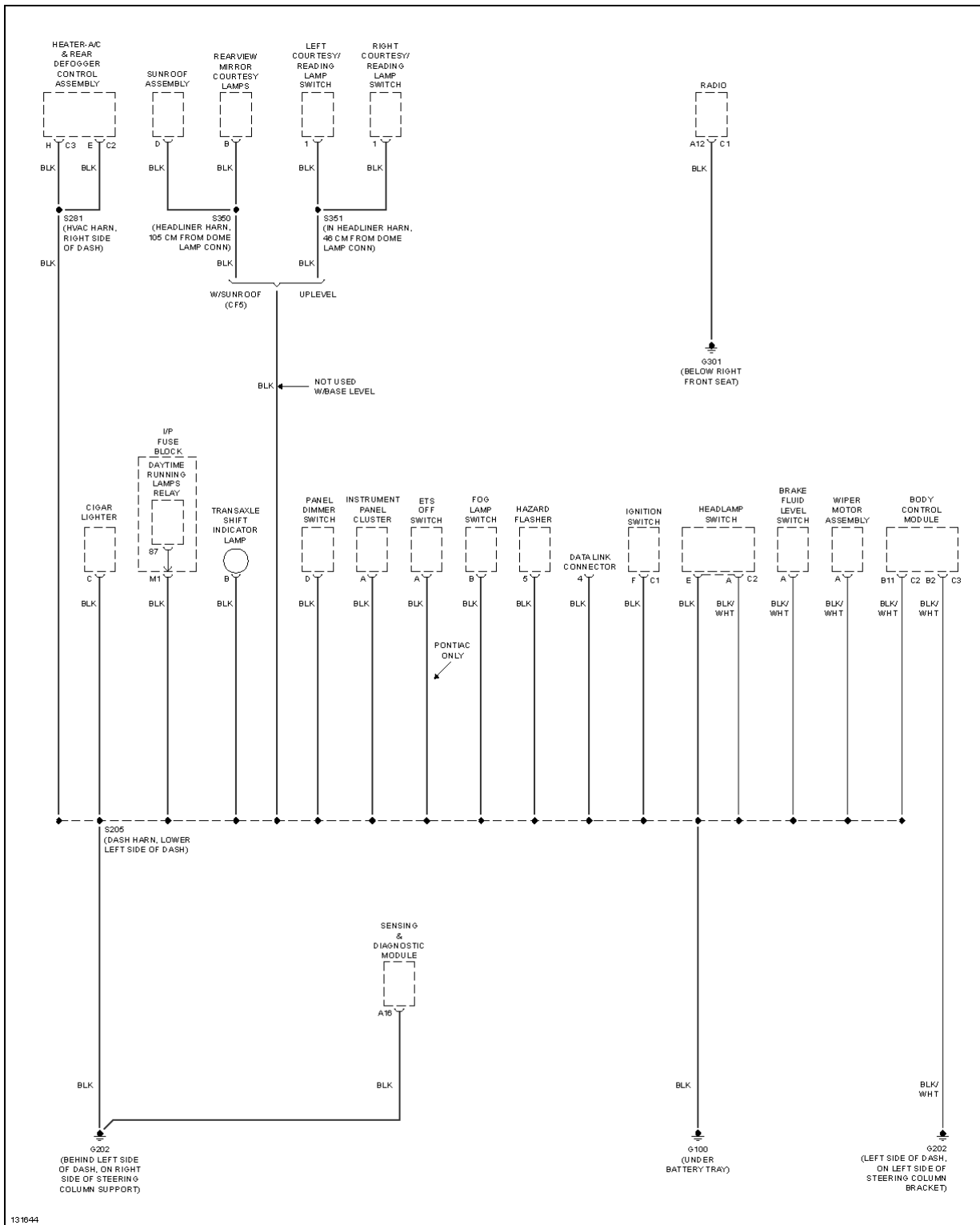
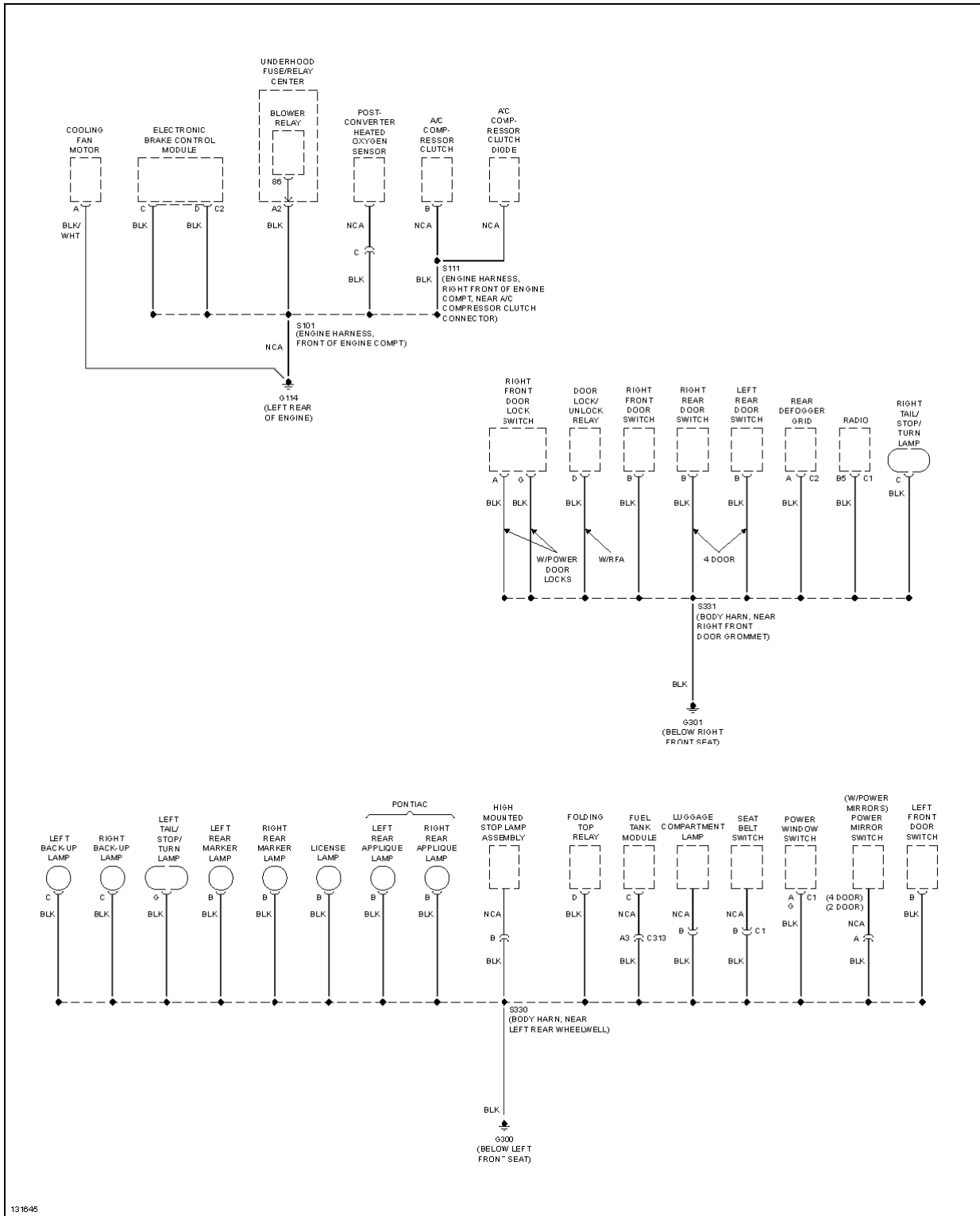



**Fig. 20: Ground Distribution Circuit (2 of 3)**

# 2000 Pontiac Sunfire SE

## 2000 System Wiring Diagrams 'Pontiac - Sunfire

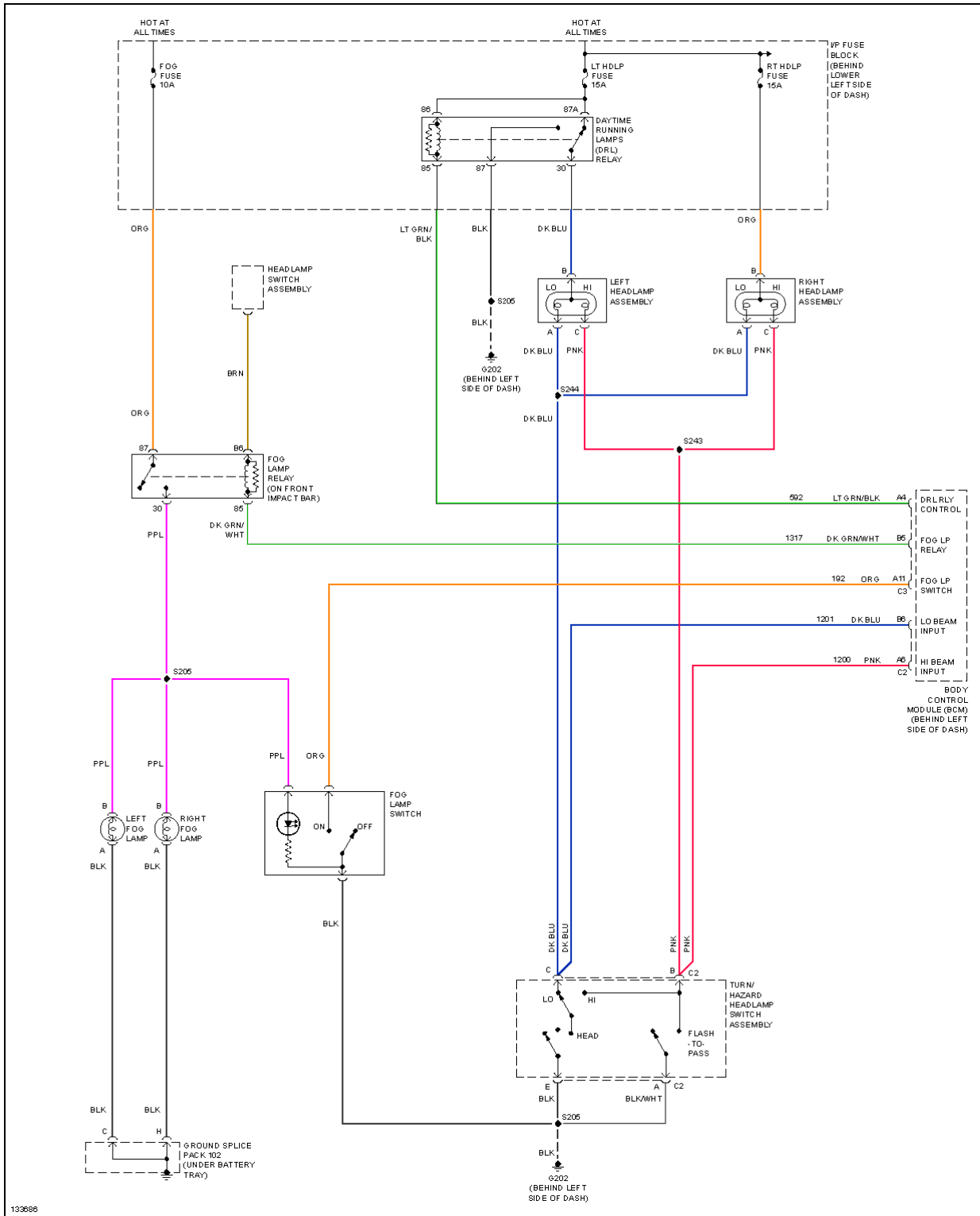

**Fig. 21: Ground Distribution Circuit (3 of 3)**

## HEADLIGHTS

# 2000 Pontiac Sunfire SE

## 2000 System Wiring Diagrams 'Pontiac - Sunfire

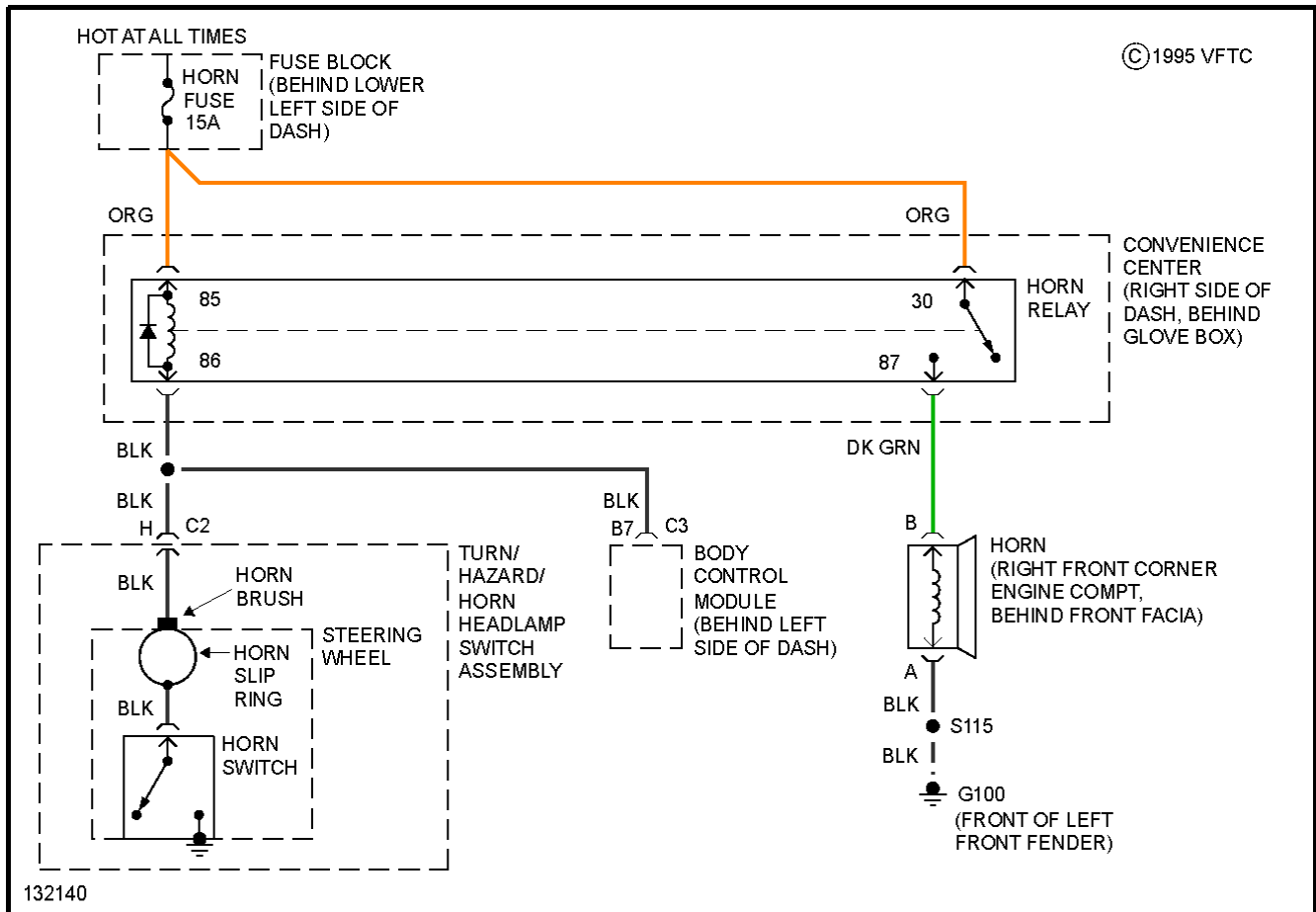

**Fig. 22: Headlight Circuit**

**HORN**

# 2000 Pontiac Sunfire SE

## 2000 System Wiring Diagrams 'Pontiac - Sunfire

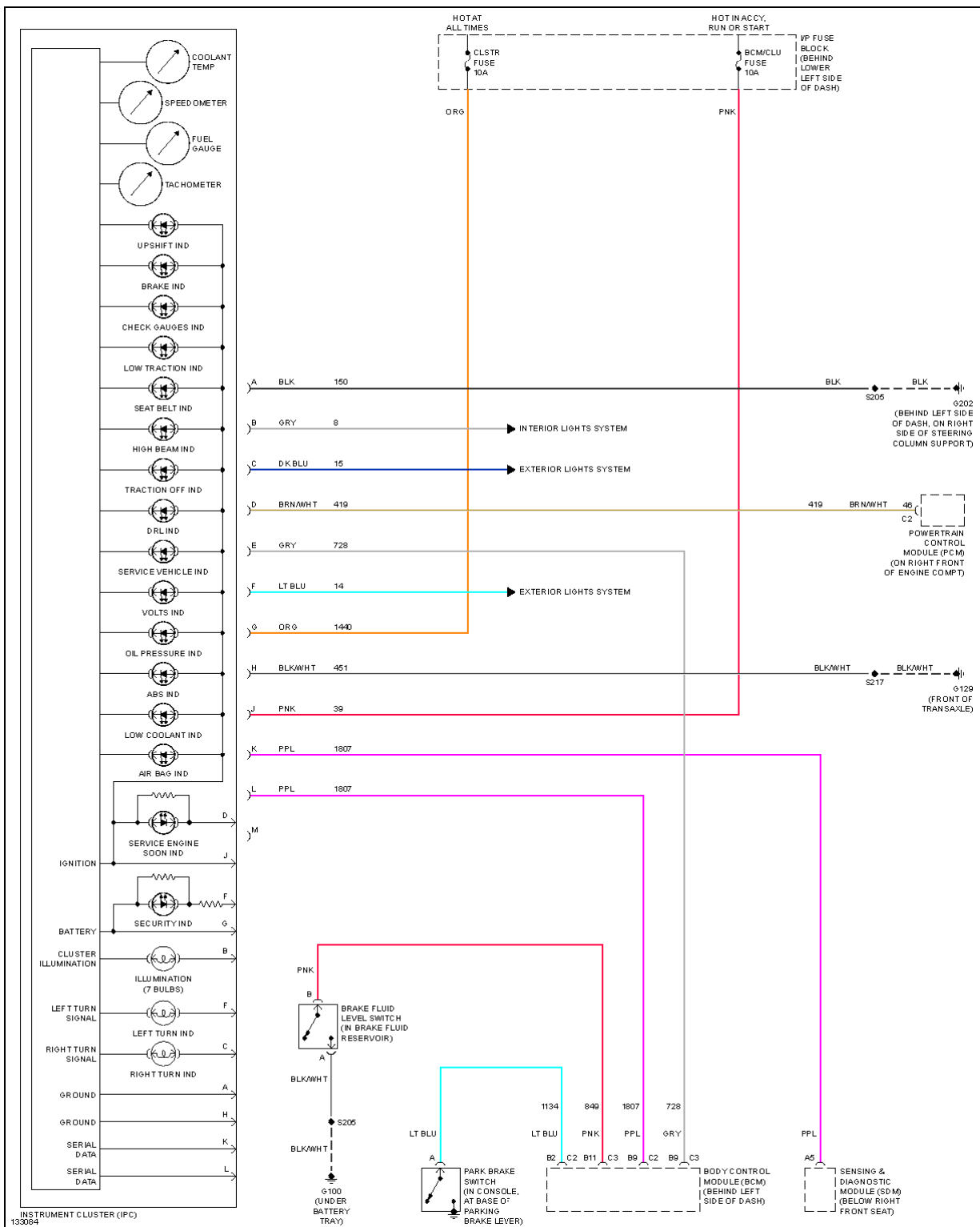

**Fig. 23: Horn Circuit**

## **INSTRUMENT CLUSTER**

# 2000 Pontiac Sunfire SE

## 2000 System Wiring Diagrams 'Pontiac - Sunfire



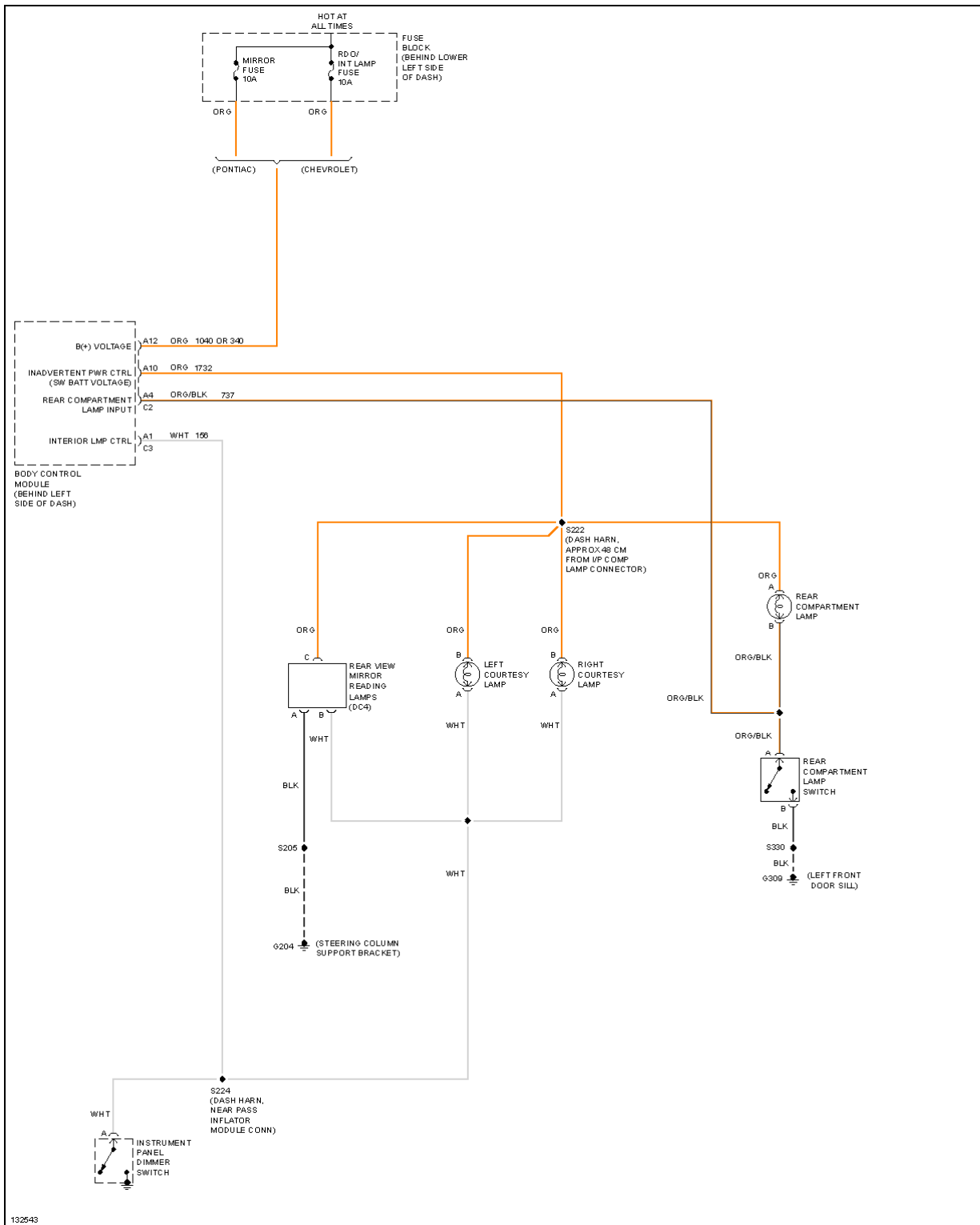

**Fig. 24: Instrument Cluster Circuit**

## INTERIOR LIGHTS

# 2000 Pontiac Sunfire SE

## 2000 System Wiring Diagrams 'Pontiac - Sunfire



132543

**Fig. 25: Courtesy Lamps Circuit, Convertible**

# 2000 Pontiac Sunfire SE

## 2000 System Wiring Diagrams 'Pontiac - Sunfire

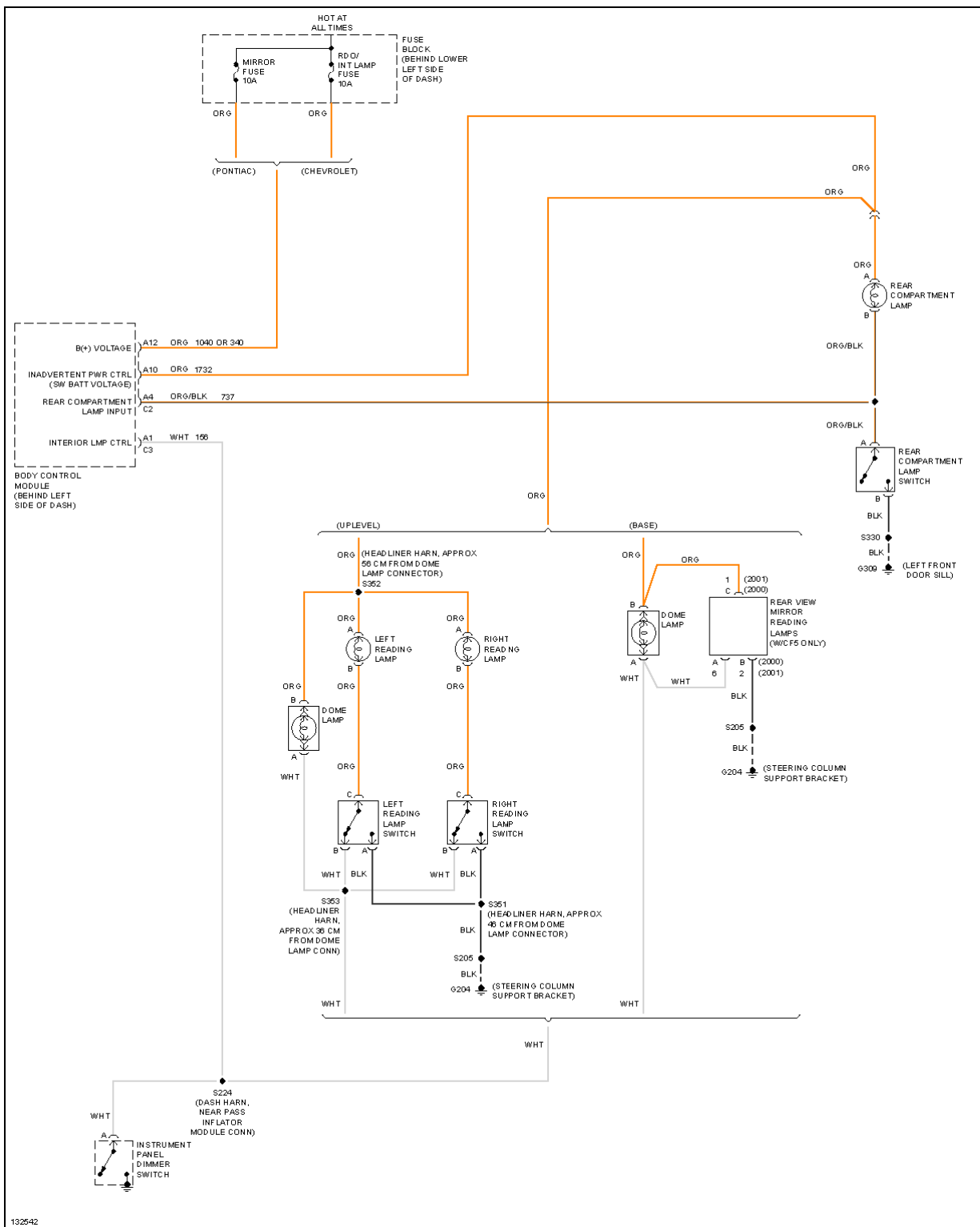

**Fig. 26: Courtesy Lamps Circuit, Coupe**

# 2000 Pontiac Sunfire SE

## 2000 System Wiring Diagrams 'Pontiac - Sunfire

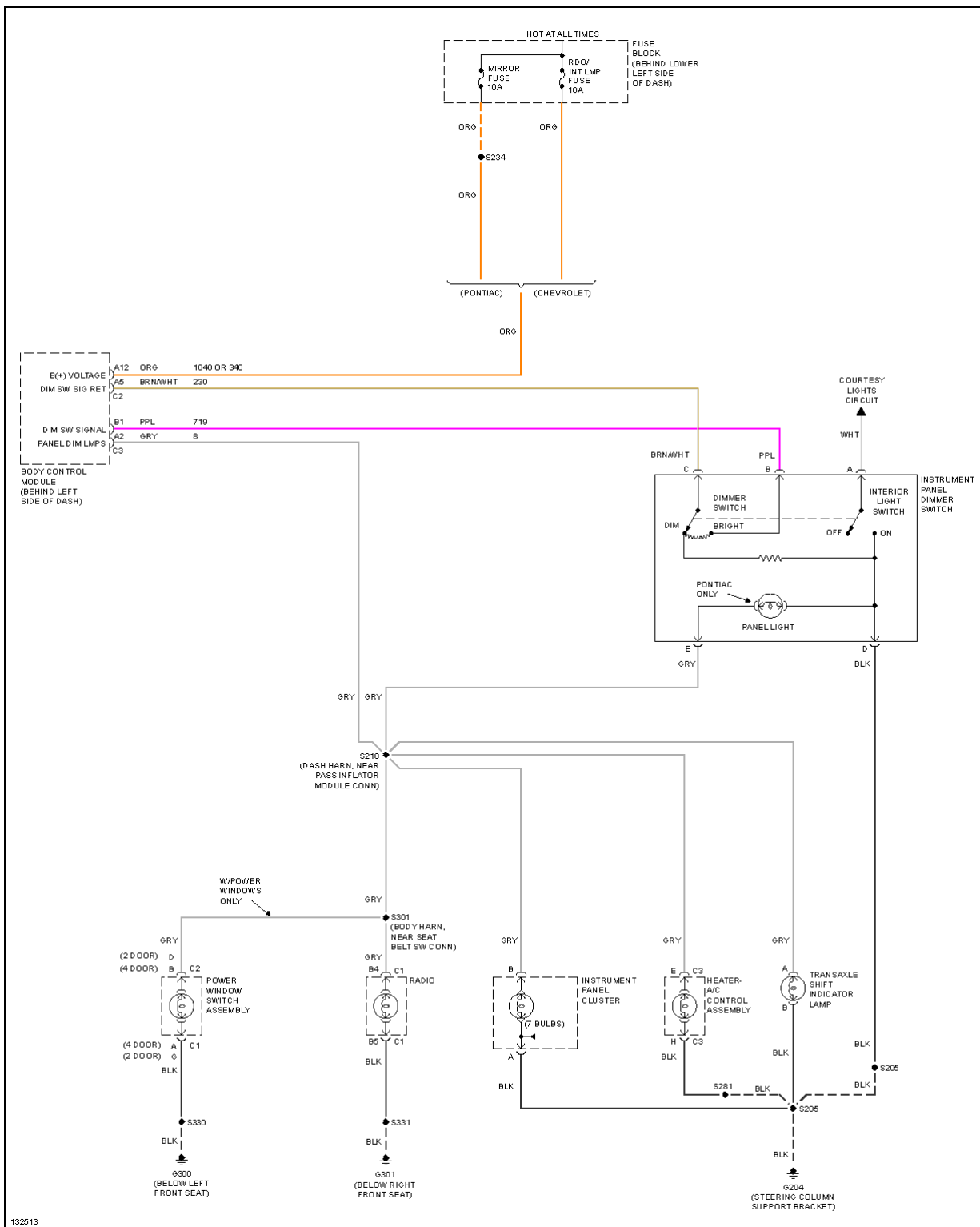

132513

**Fig. 27: Instrument Illumination Circuit**

**POWER DISTRIBUTION**

# 2000 Pontiac Sunfire SE

## 2000 System Wiring Diagrams 'Pontiac - Sunfire

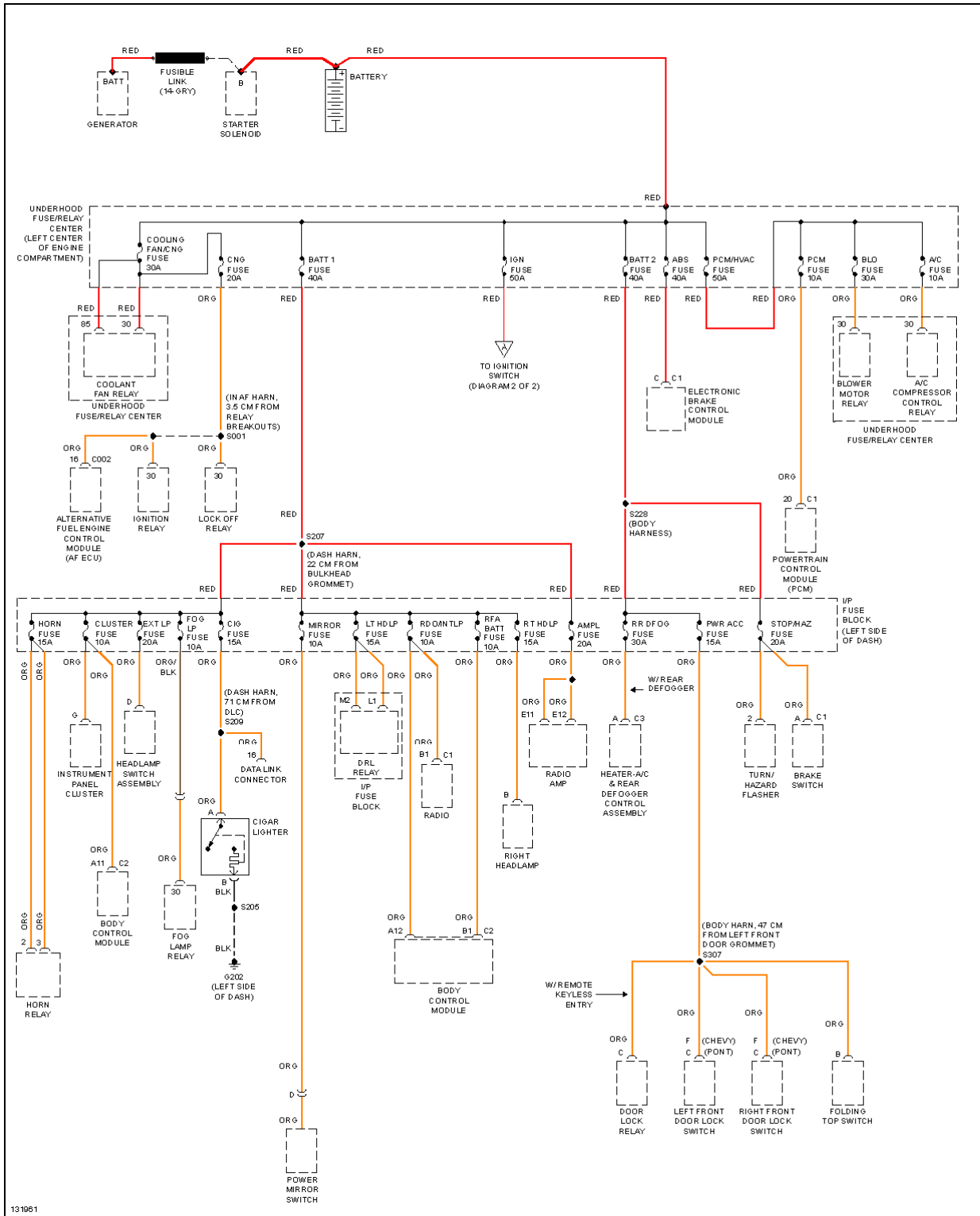

131961



**Fig. 28: Power Distribution Circuit (1 of 2)**

# 2000 Pontiac Sunfire SE

## 2000 System Wiring Diagrams 'Pontiac - Sunfire

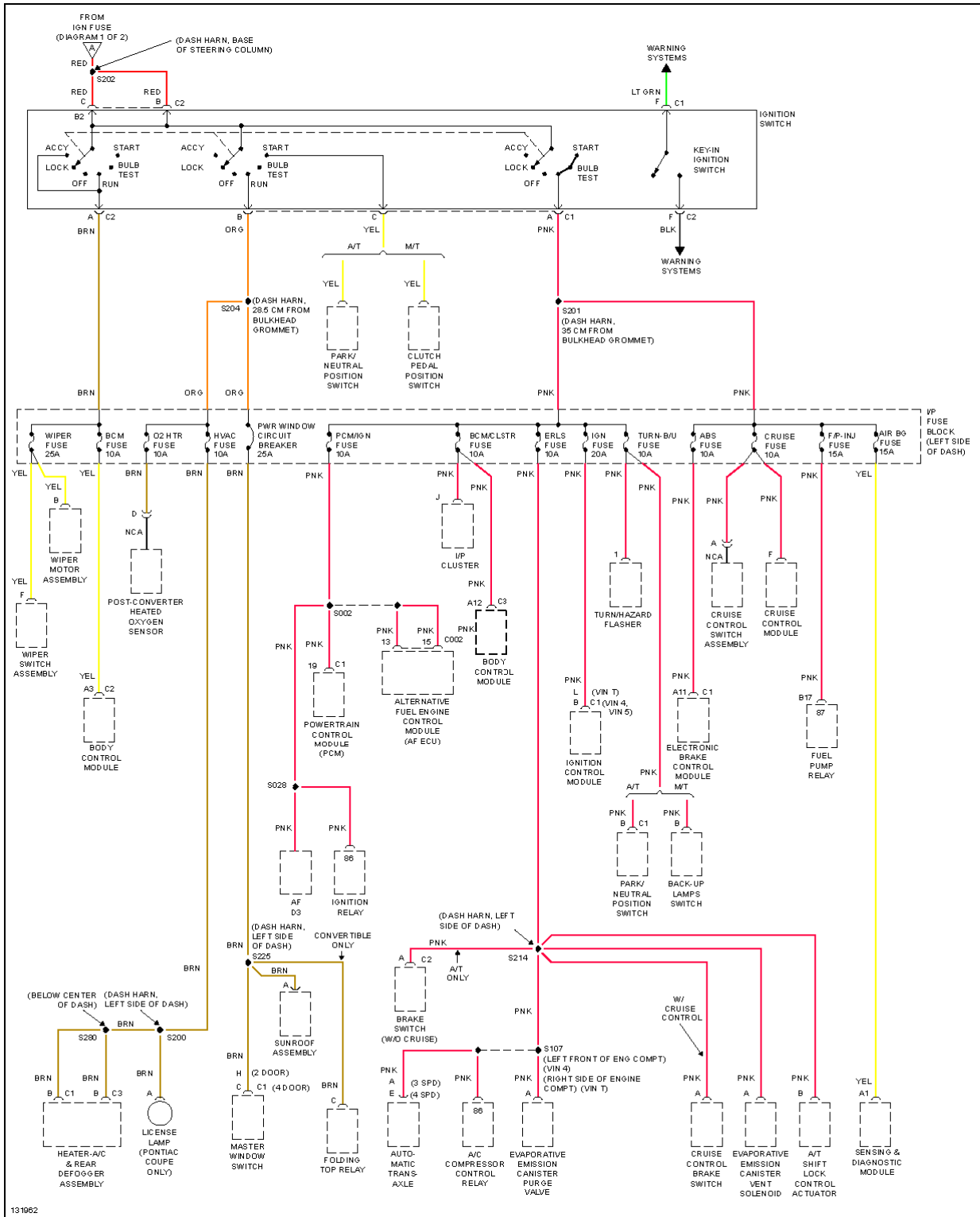

131962

**Fig. 29: Power Distribution Circuit (2 of 2)**

## POWER DOOR LOCKS

# 2000 Pontiac Sunfire SE

## 2000 System Wiring Diagrams 'Pontiac - Sunfire

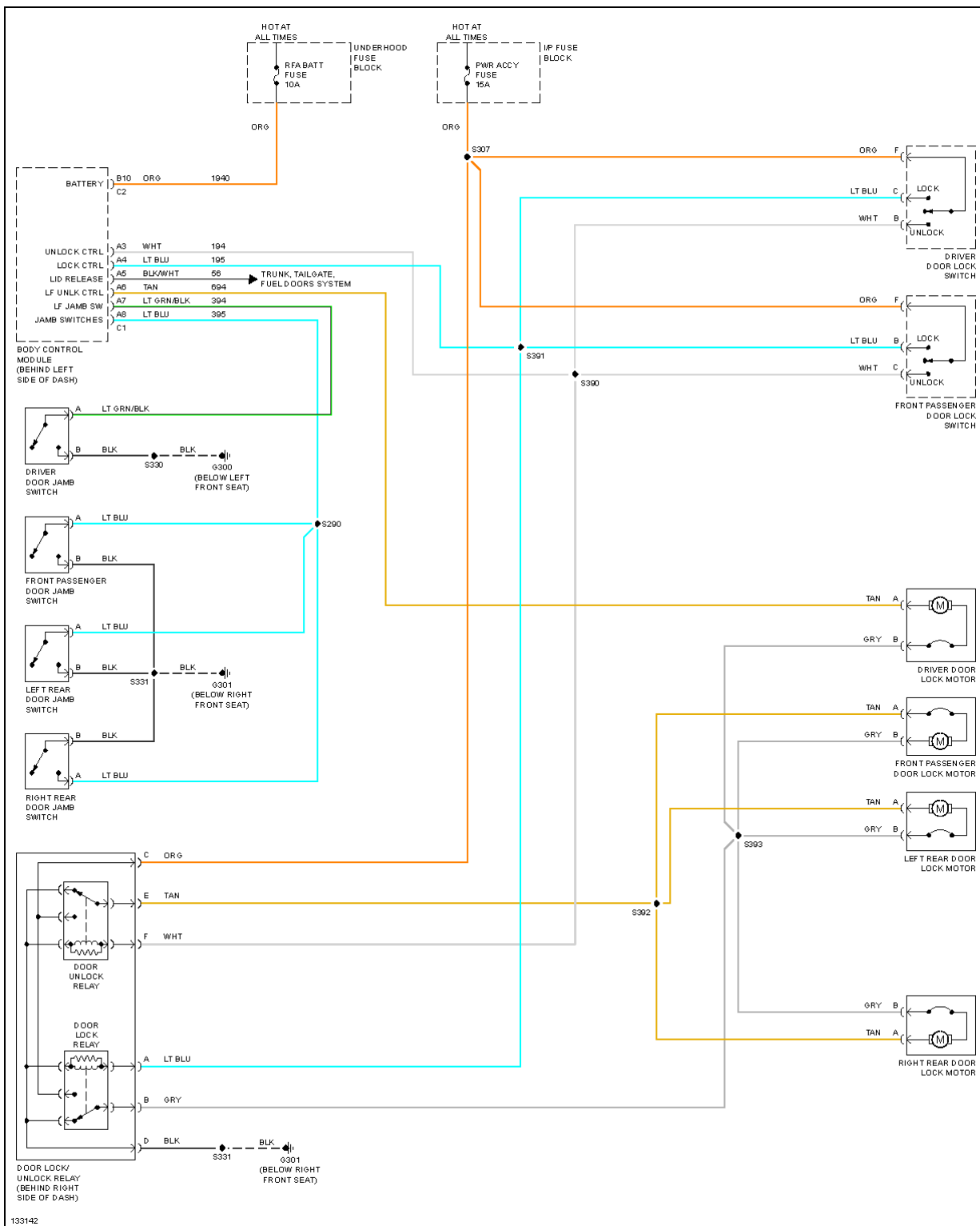

**Fig. 30: Power Door Lock Circuit, W/ Keyless Entry**

# 2000 Pontiac Sunfire SE

## 2000 System Wiring Diagrams 'Pontiac - Sunfire

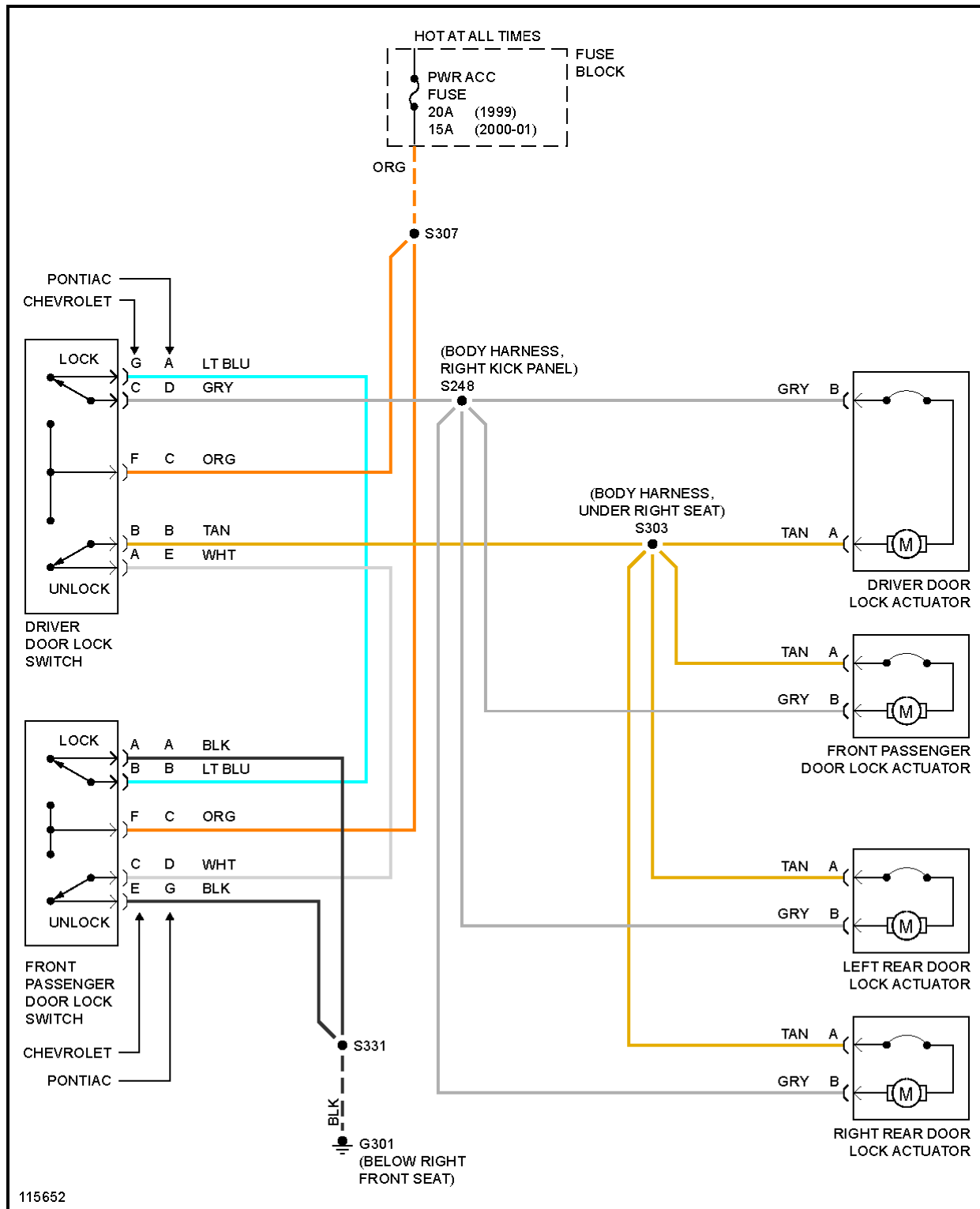
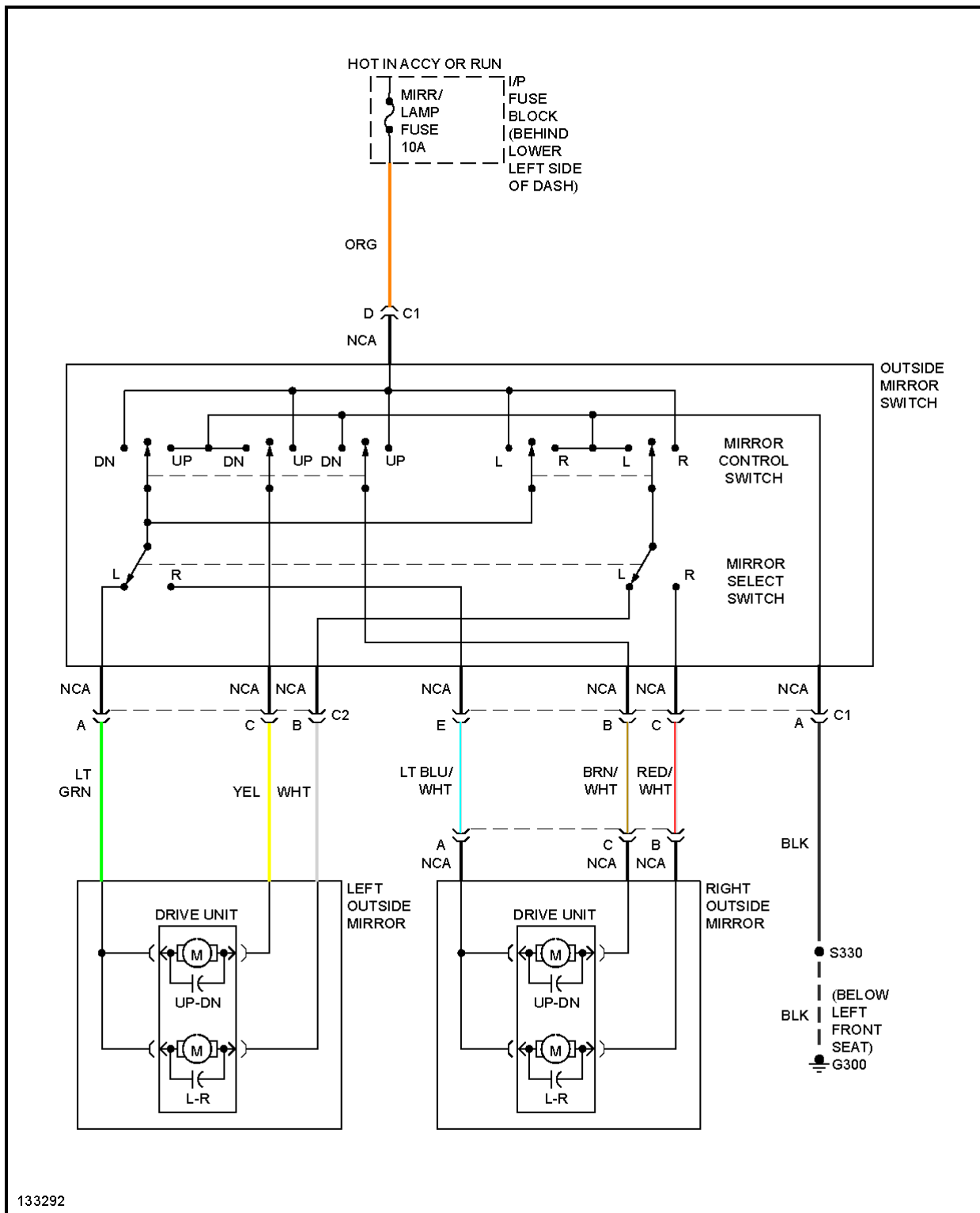

**Fig. 31: Power Door Lock Circuit, W/O Keyless Entry**

## **POWER MIRRORS**

# 2000 Pontiac Sunfire SE

## 2000 System Wiring Diagrams 'Pontiac - Sunfire



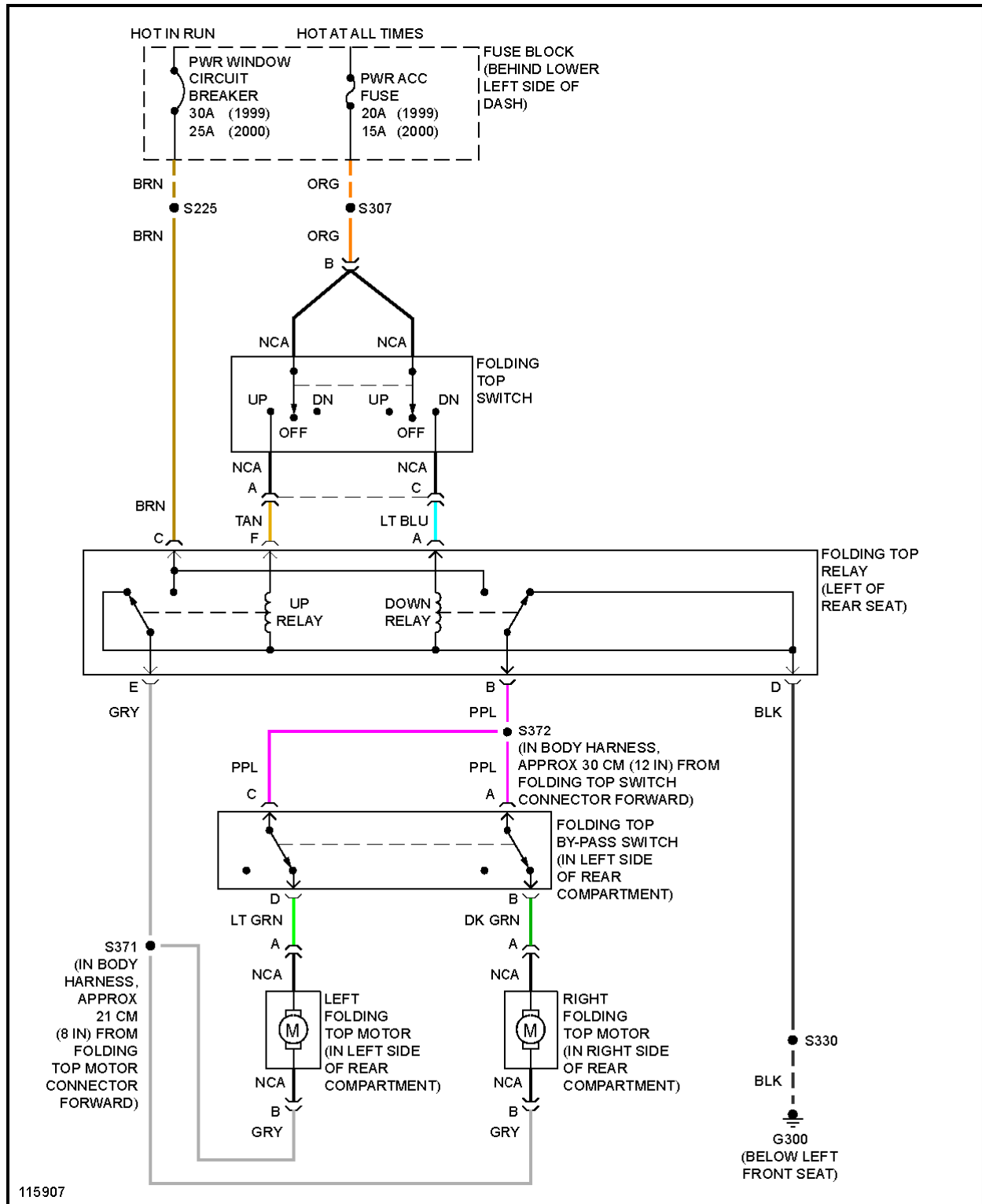

**Fig. 32: Power Mirror Circuit**

**POWER TOP/SUNROOF**

# 2000 Pontiac Sunfire SE

## 2000 System Wiring Diagrams 'Pontiac - Sunfire



**Fig. 33: Convertible Top Circuit**

# 2000 Pontiac Sunfire SE

## 2000 System Wiring Diagrams 'Pontiac - Sunfire

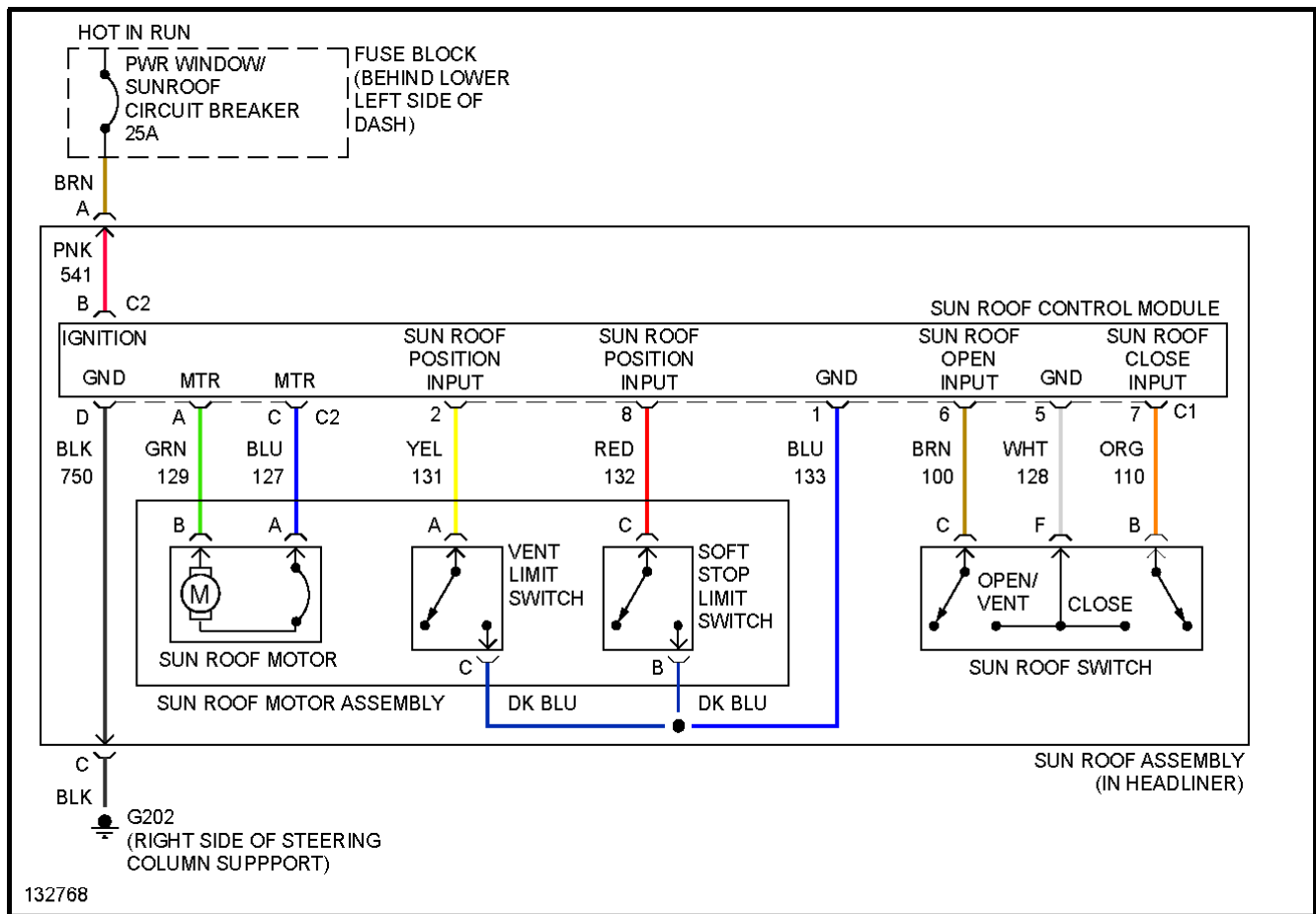
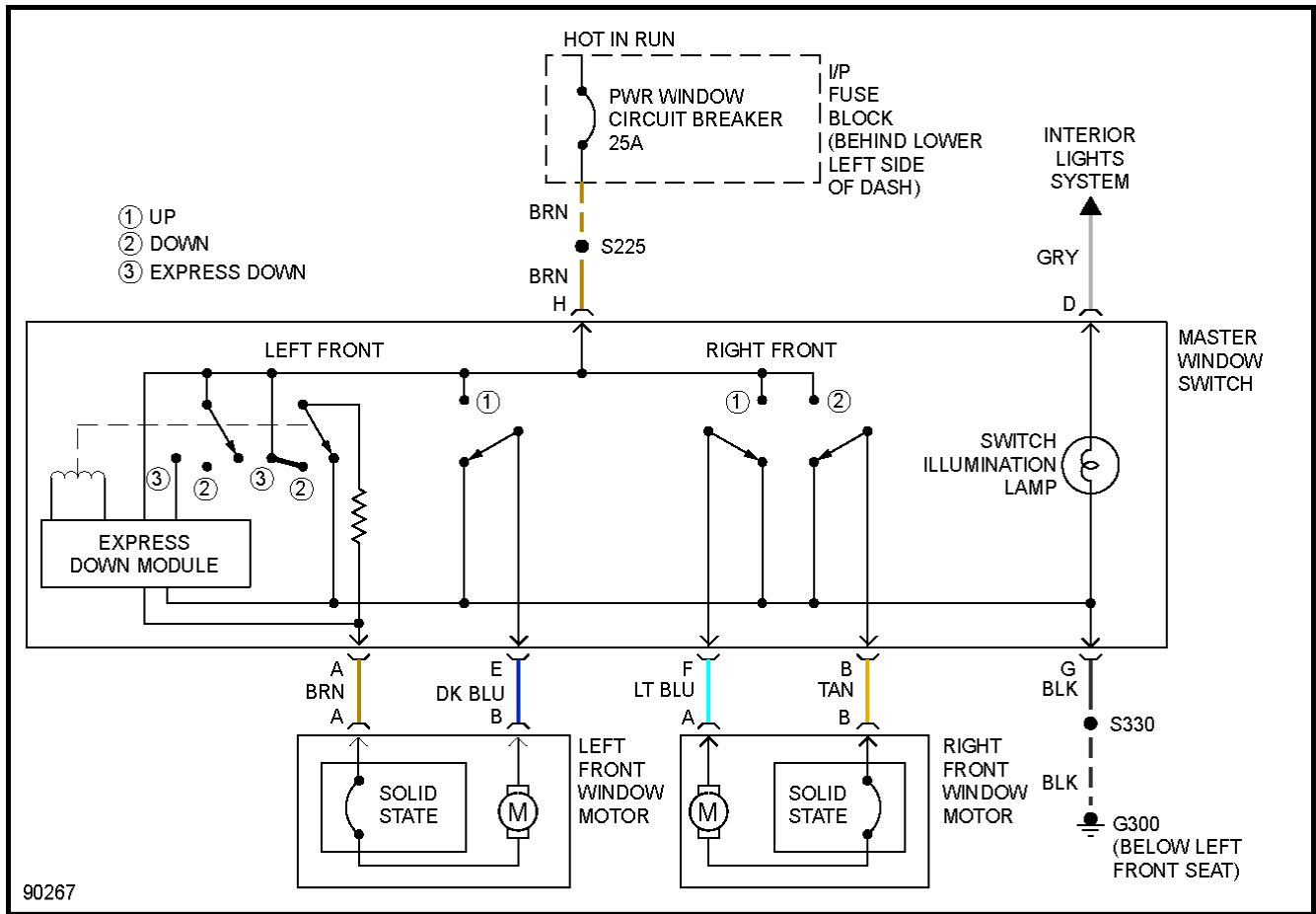

**Fig. 34: Sunroof Circuit**

**POWER WINDOWS**

# 2000 Pontiac Sunfire SE

## 2000 System Wiring Diagrams 'Pontiac - Sunfire



**Fig. 35: Power Window Circuit, 2 Door**

# 2000 Pontiac Sunfire SE

## 2000 System Wiring Diagrams 'Pontiac - Sunfire

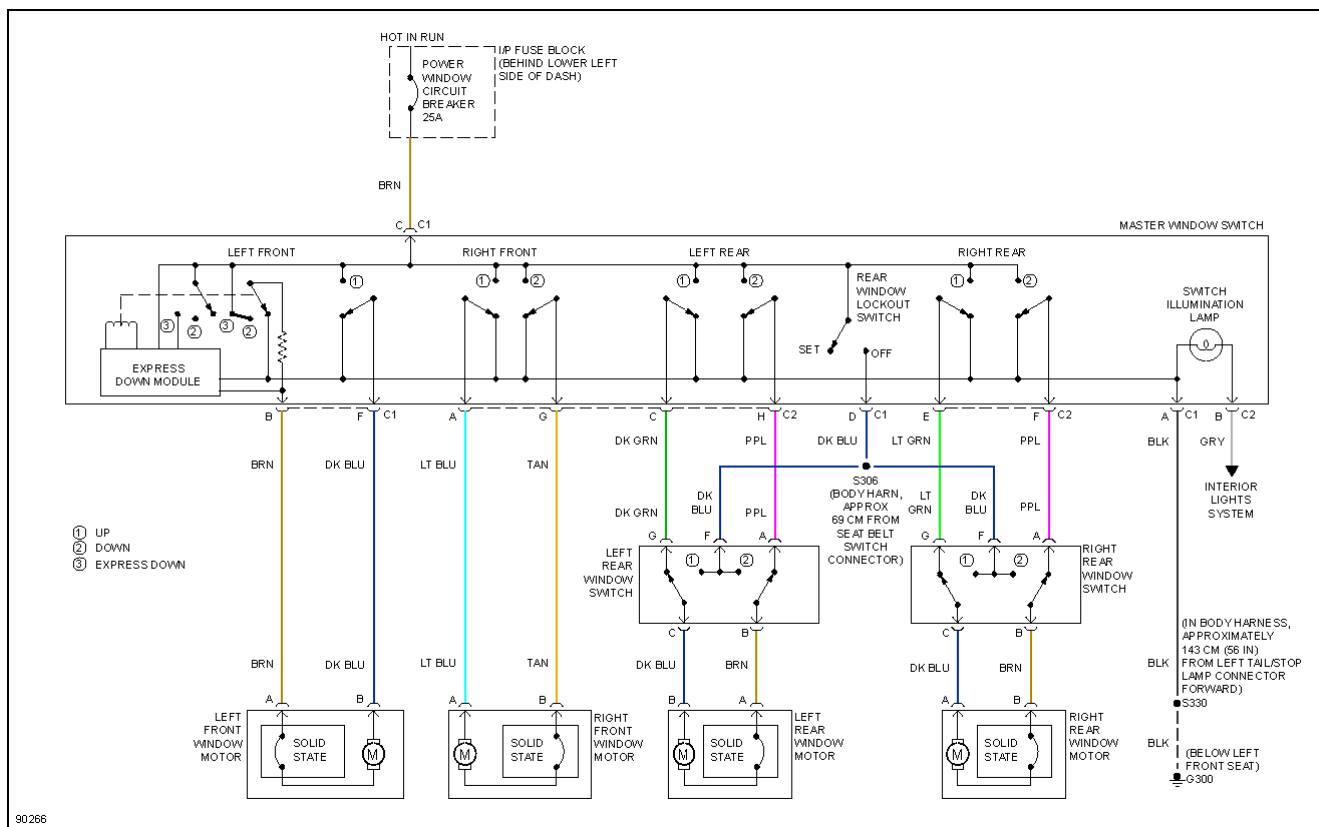

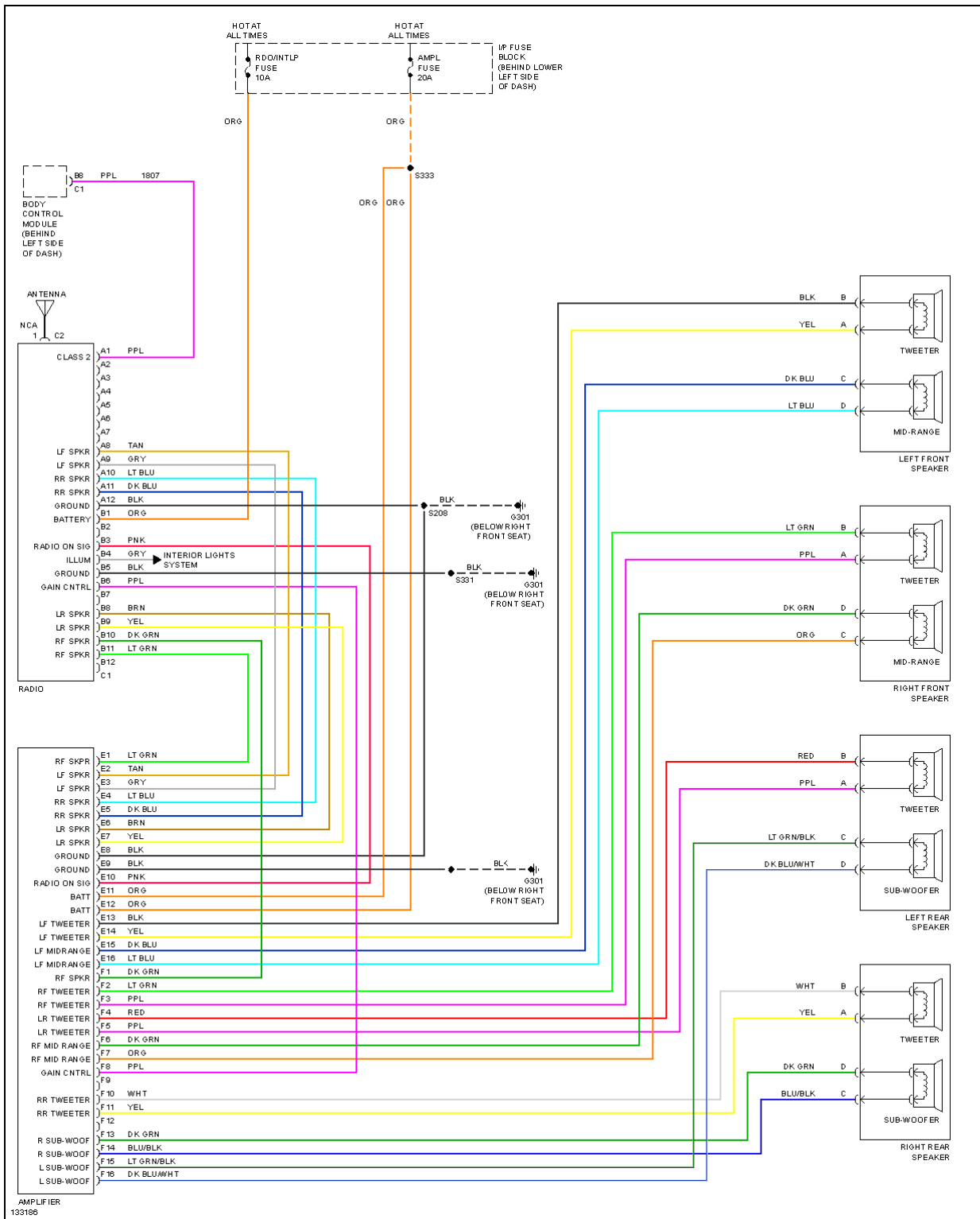

**Fig. 36: Power Window Circuit, 4 Door**

**RADIO**

# 2000 Pontiac Sunfire SE

## 2000 System Wiring Diagrams 'Pontiac - Sunfire



**Fig. 37: Radio Circuits, W/ Amplifier**

# 2000 Pontiac Sunfire SE

## 2000 System Wiring Diagrams 'Pontiac - Sunfire

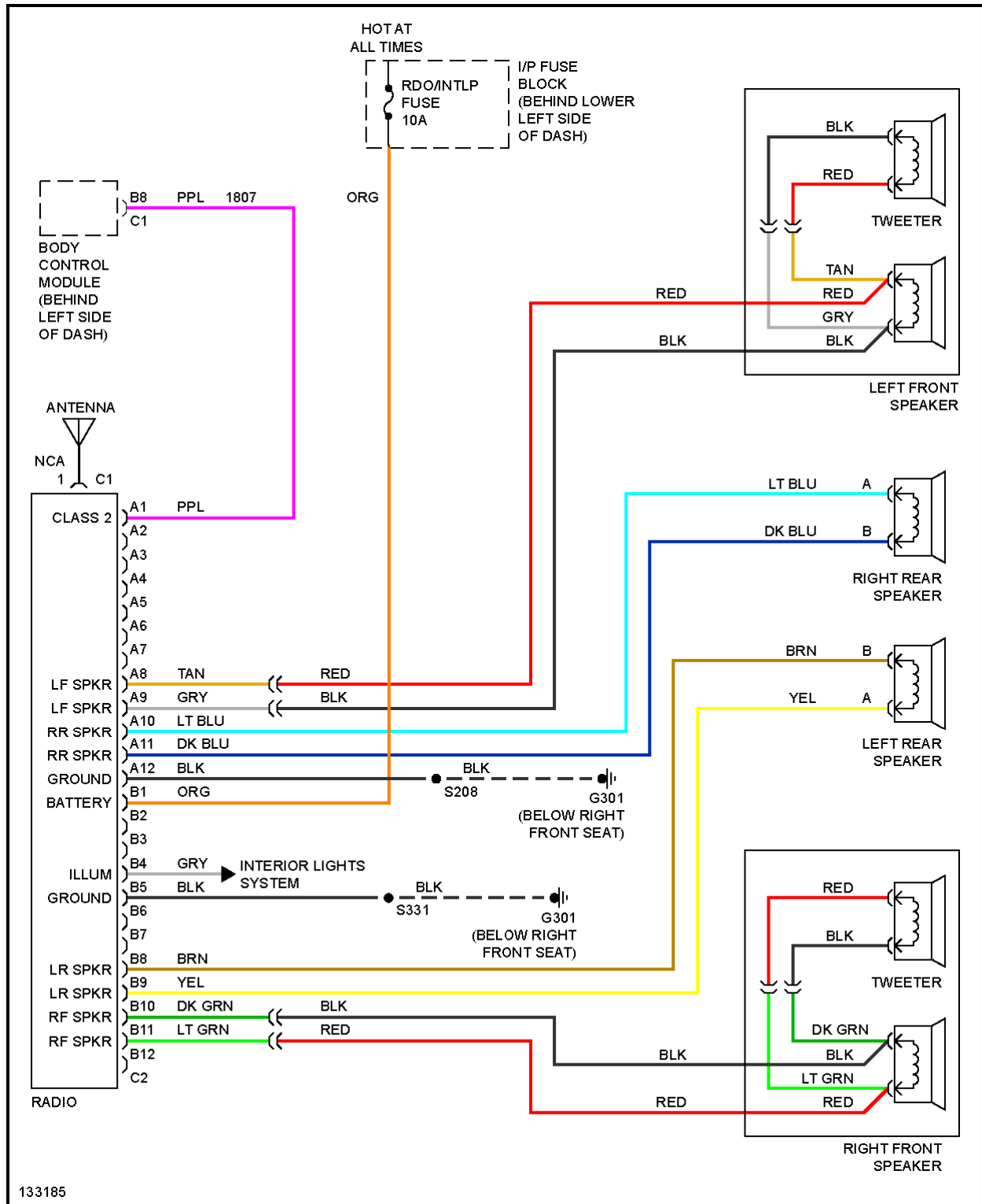
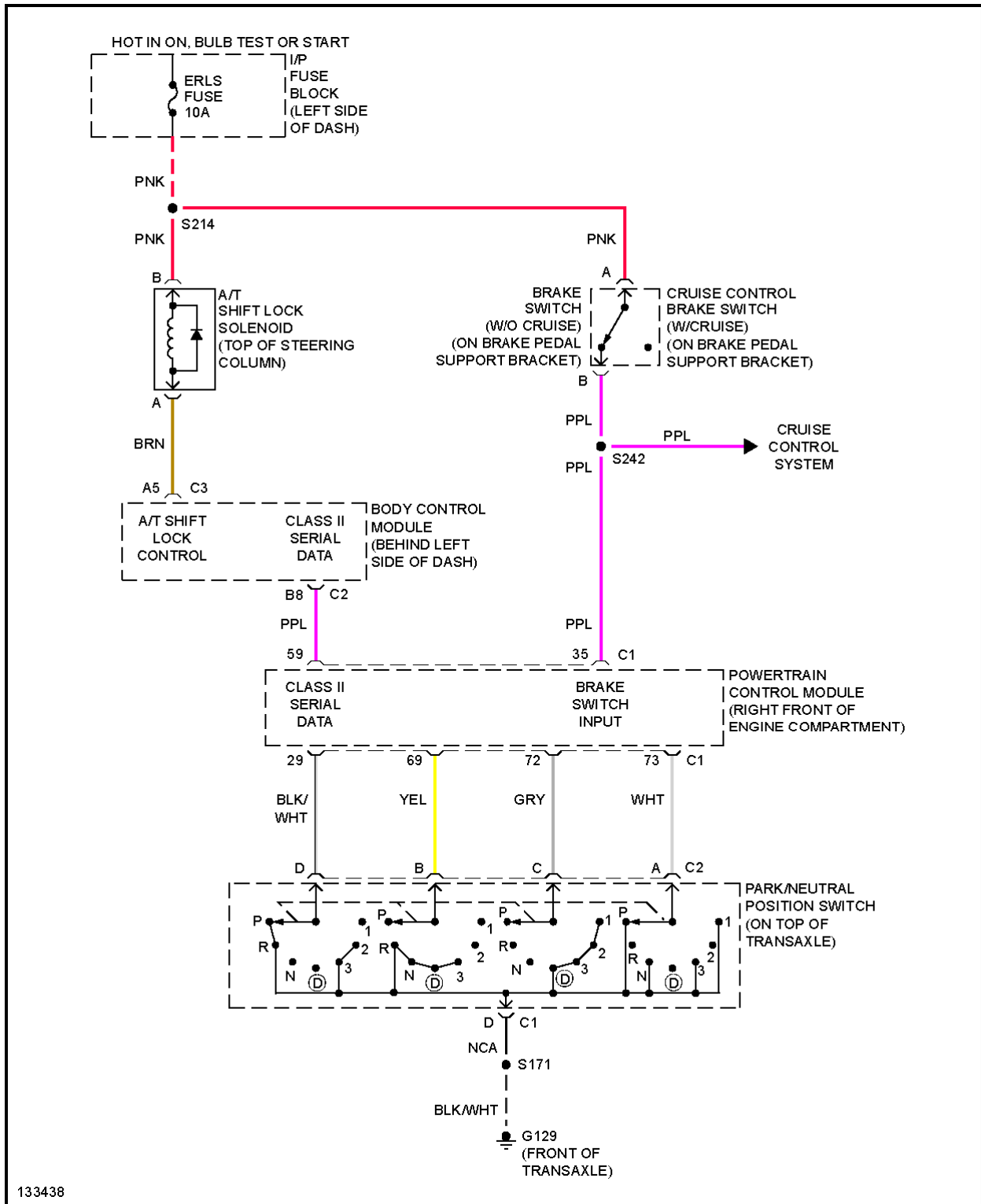

**Fig. 38: Radio Circuits, W/O Amplifier**

## SHIFT INTERLOCKS

# 2000 Pontiac Sunfire SE

## 2000 System Wiring Diagrams 'Pontiac - Sunfire

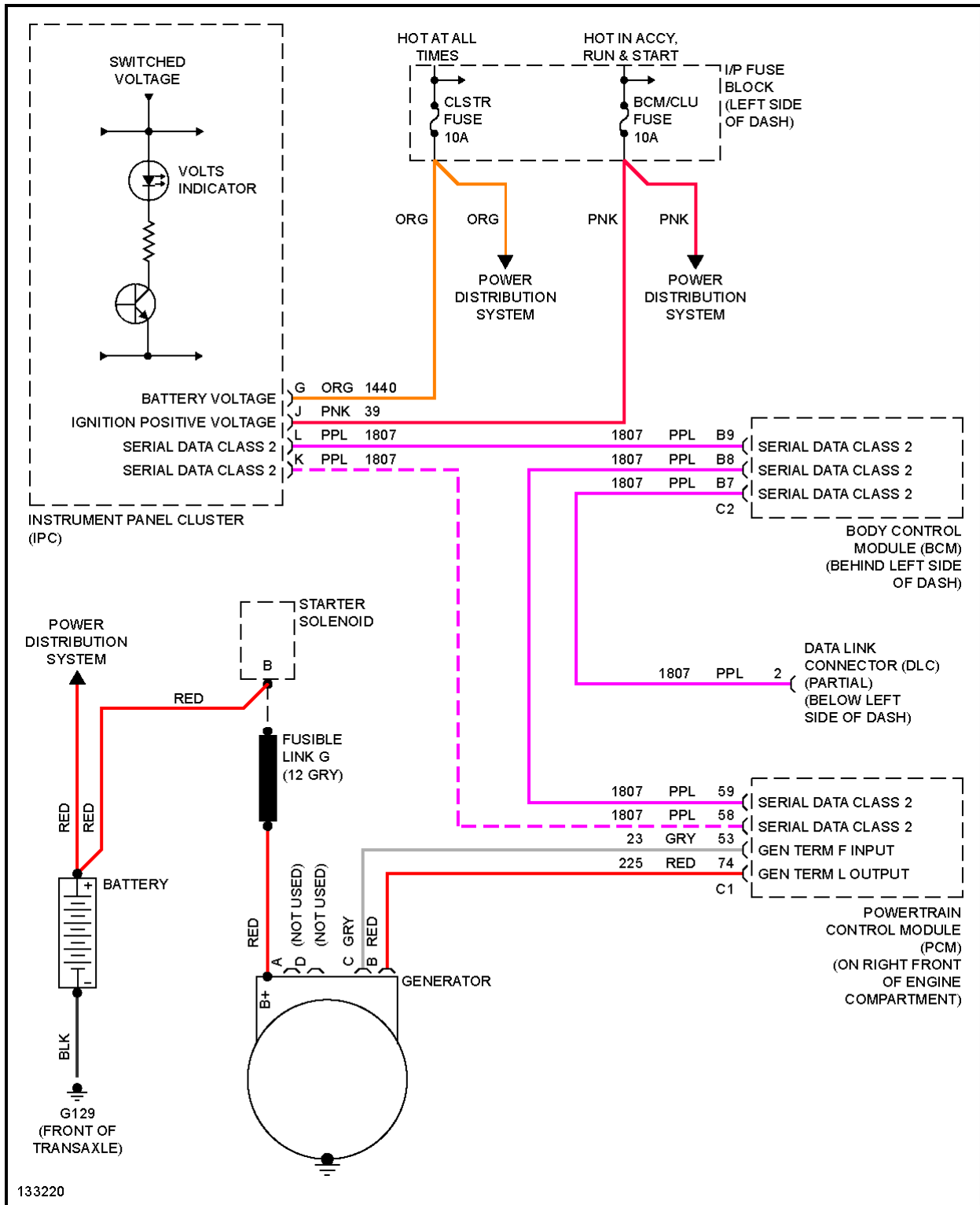

**Fig. 39: Shift Interlock Circuit**

**STARTING/CHARGING**

# 2000 Pontiac Sunfire SE

## 2000 System Wiring Diagrams 'Pontiac - Sunfire

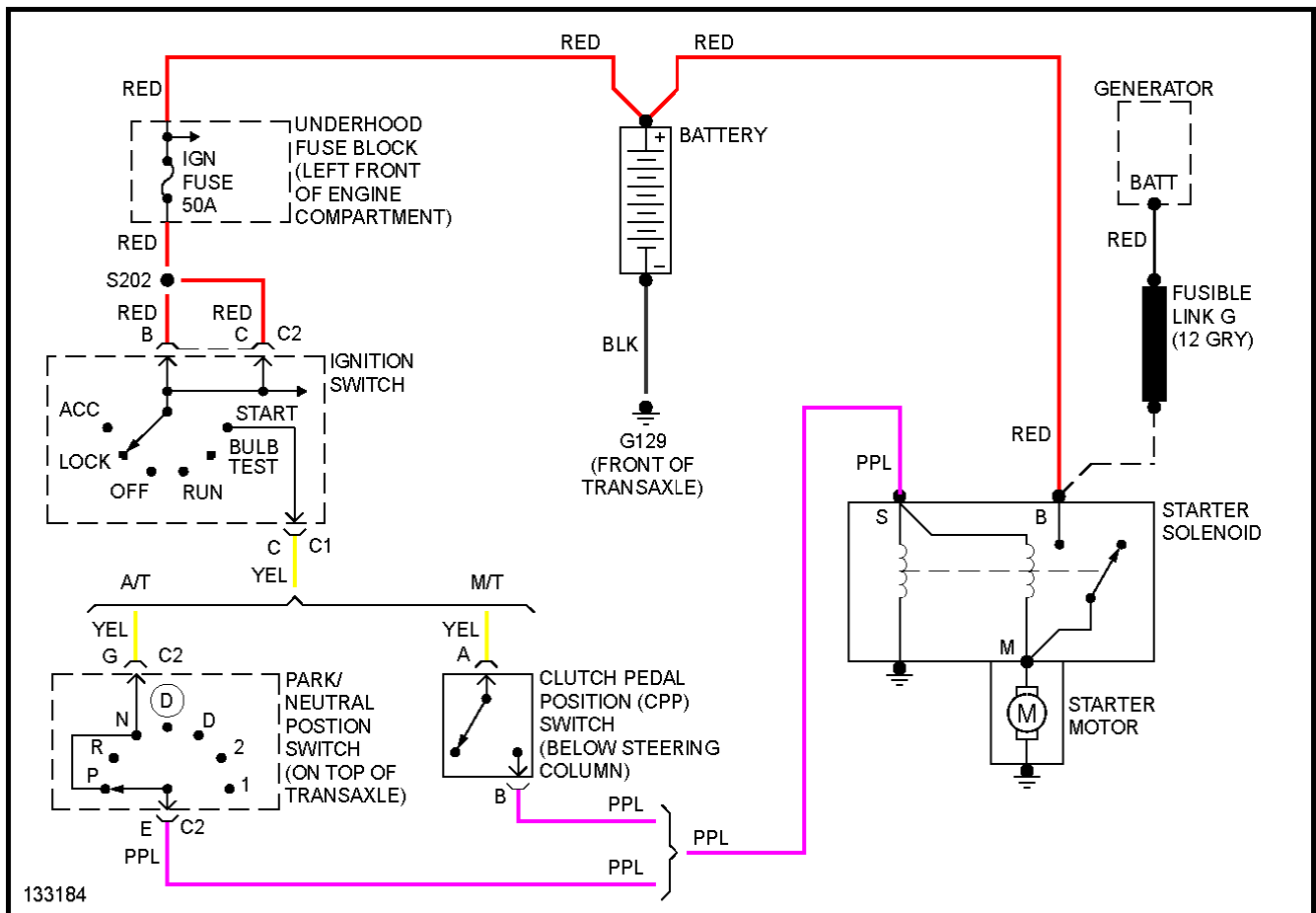



**Fig. 40: Charging Circuit**

# 2000 Pontiac Sunfire SE

## 2000 System Wiring Diagrams 'Pontiac - Sunfire

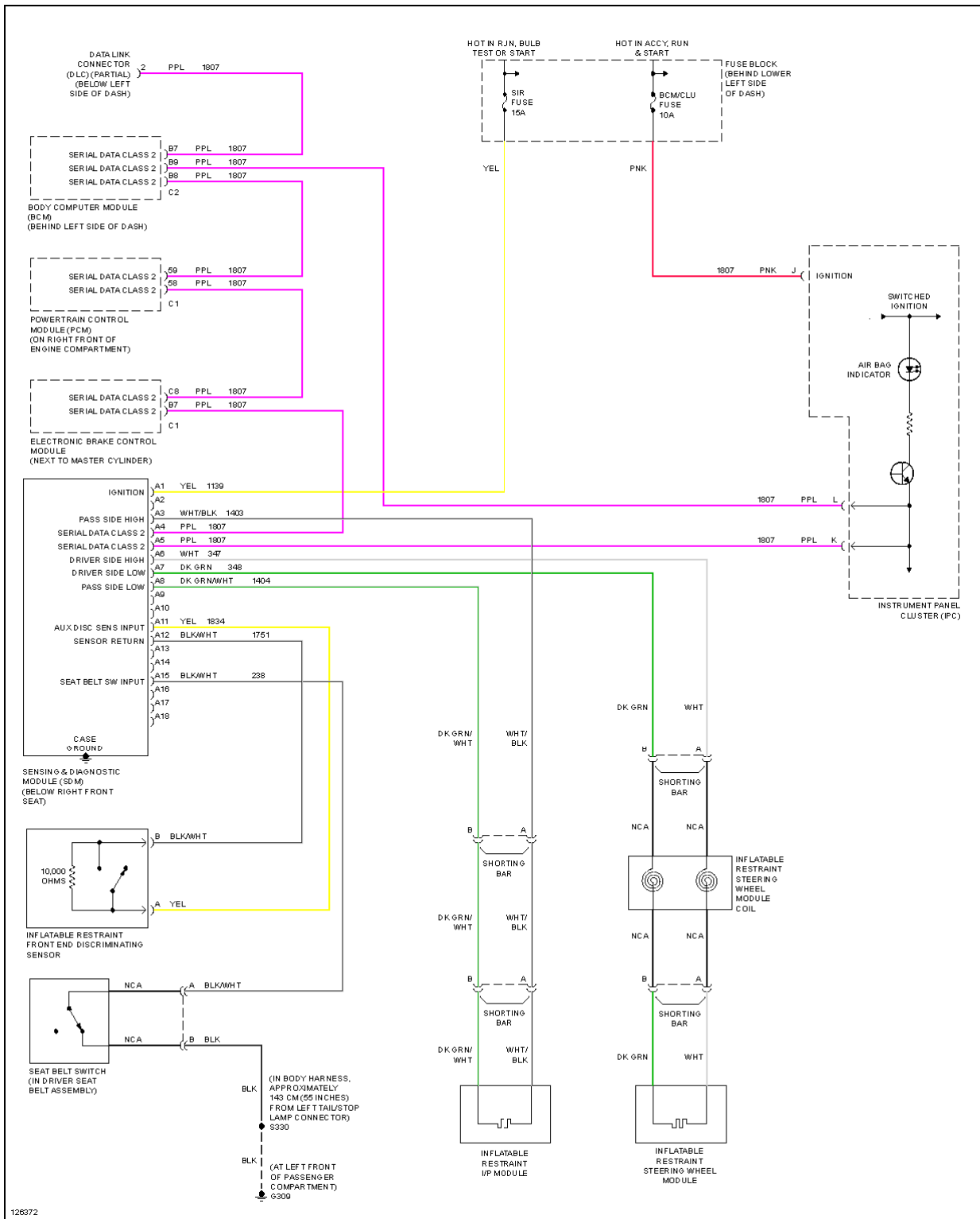

**Fig. 41: Starting Circuit**

**SUPPLEMENTAL RESTRAINTS**

# 2000 Pontiac Sunfire SE

## 2000 System Wiring Diagrams 'Pontiac - Sunfire



**Fig. 42: Supplemental Restraint Circuit**

## TRANSMISSION

2.2L

# 2000 Pontiac Sunfire SE

## 2000 System Wiring Diagrams 'Pontiac - Sunfire

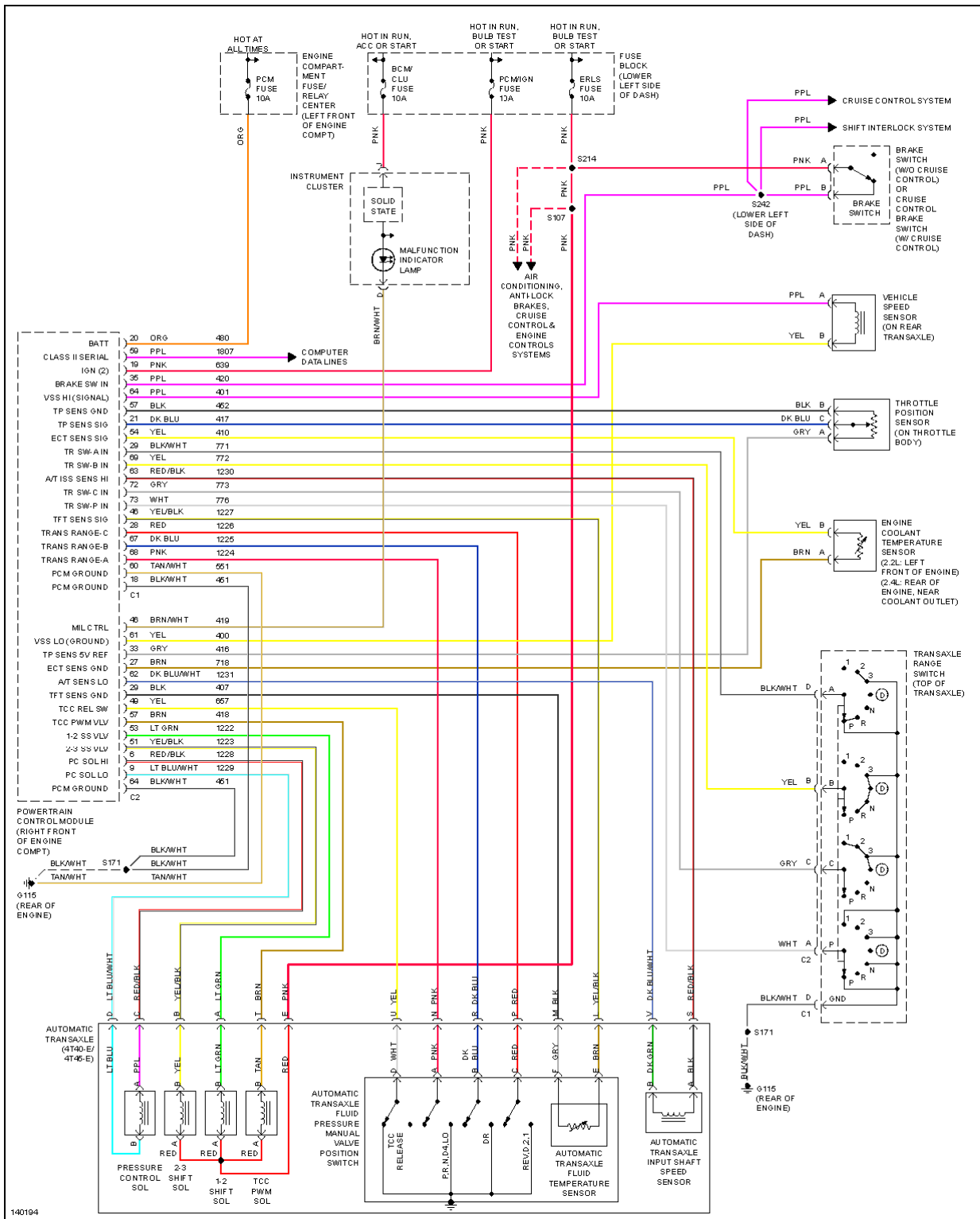

**Fig. 43: 2.2L VIN 4, A/T Circuit**

# 2000 Pontiac Sunfire SE

## 2000 System Wiring Diagrams 'Pontiac - Sunfire

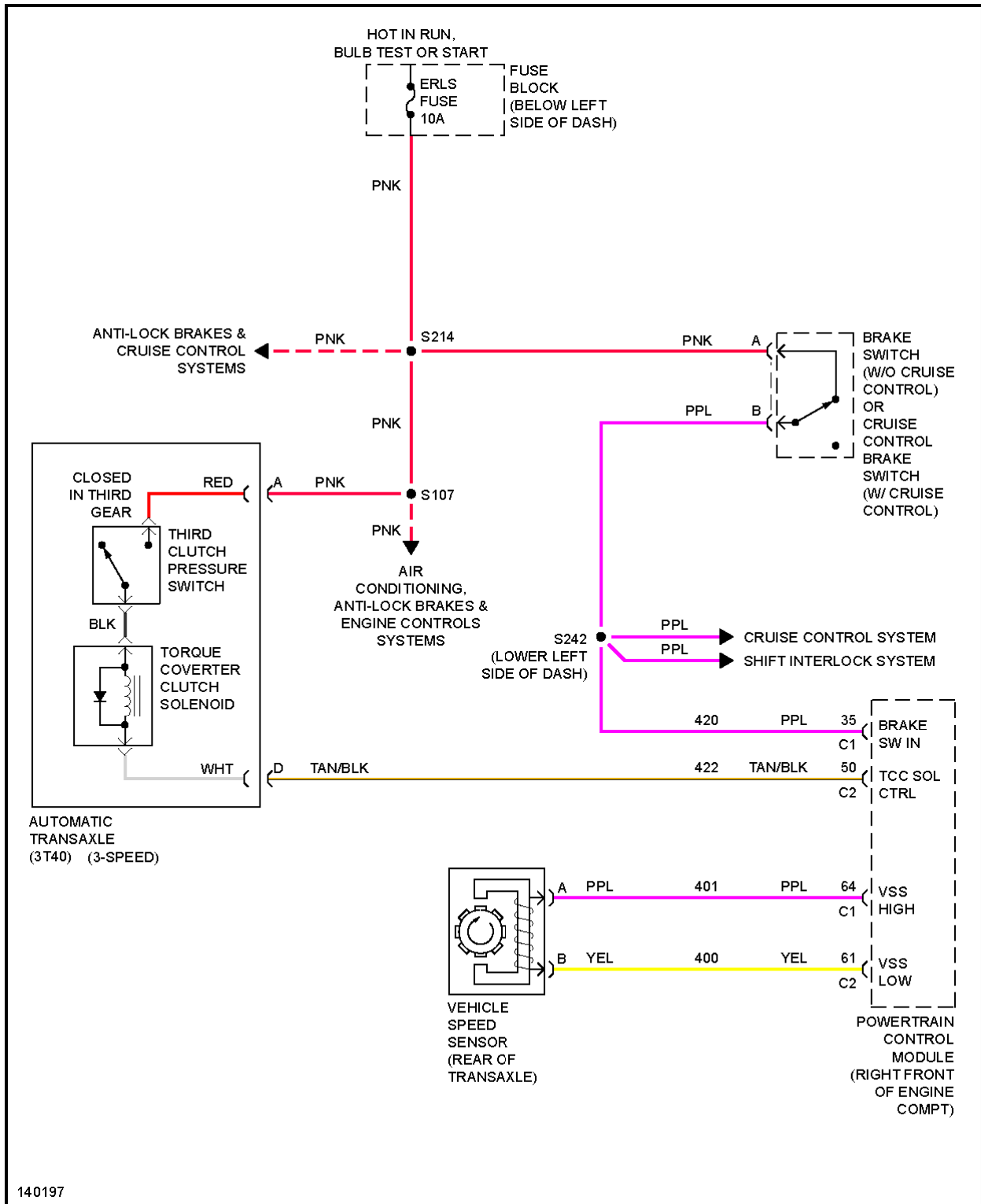

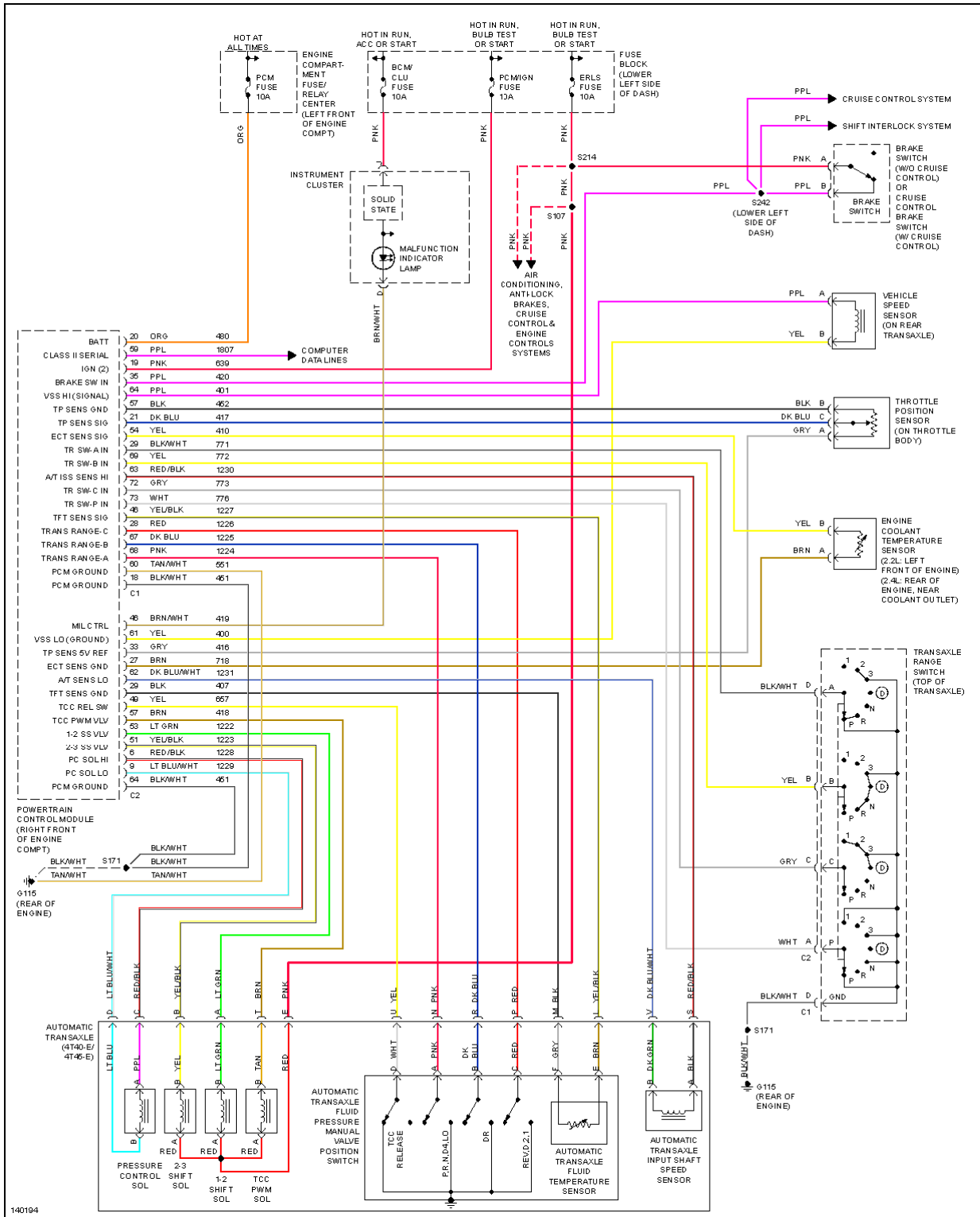

**Fig. 44: 2.2L VIN 4, TCC Solenoid Circuit**

2.4L

# 2000 Pontiac Sunfire SE

## 2000 System Wiring Diagrams 'Pontiac - Sunfire



140194

**Fig. 45: 2.4L VIN T, A/T Circuit**

**TRUNK, TAILGATE, FUEL DOOR**

# 2000 Pontiac Sunfire SE

## 2000 System Wiring Diagrams' 'Pontiac - Sunfire

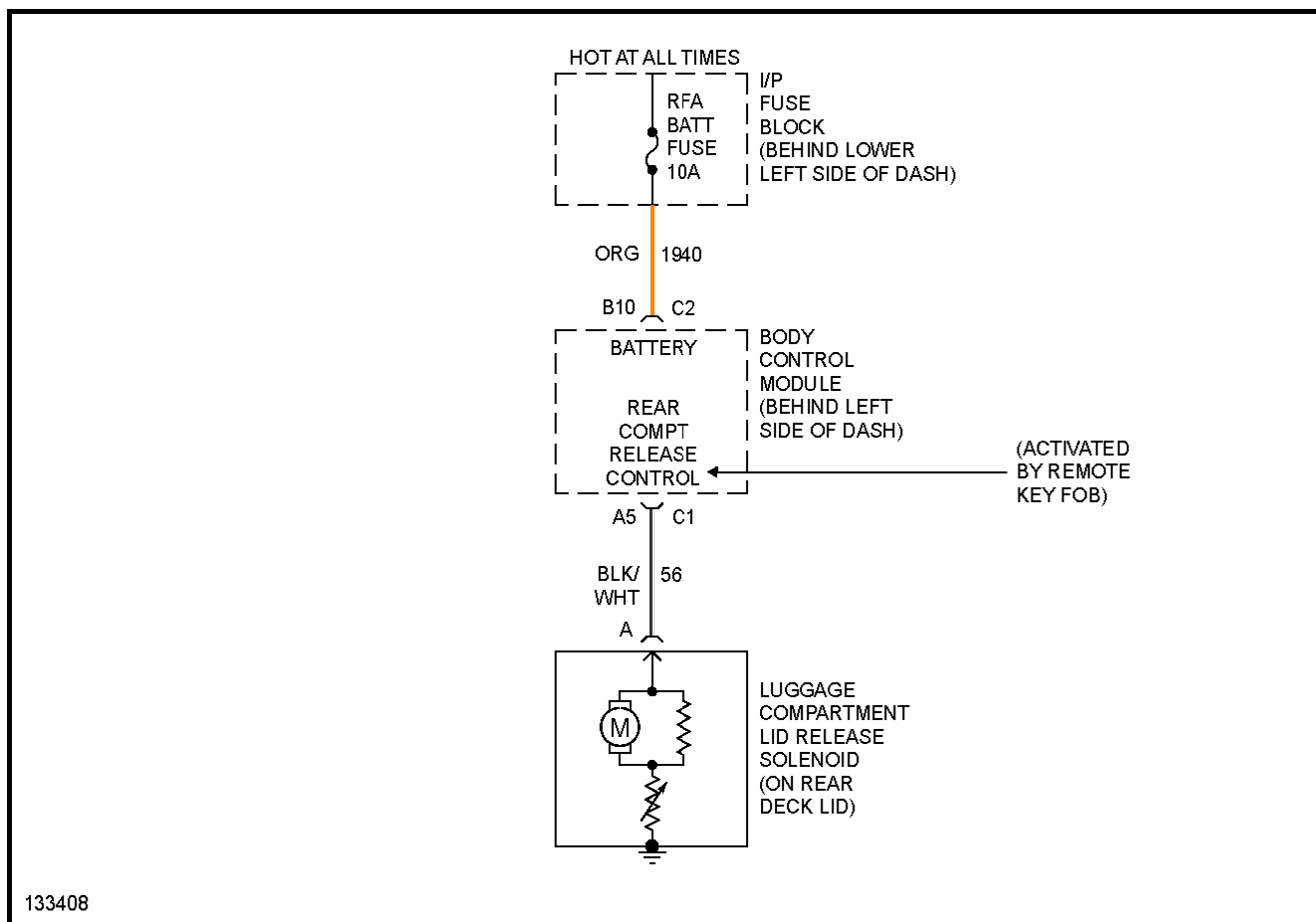
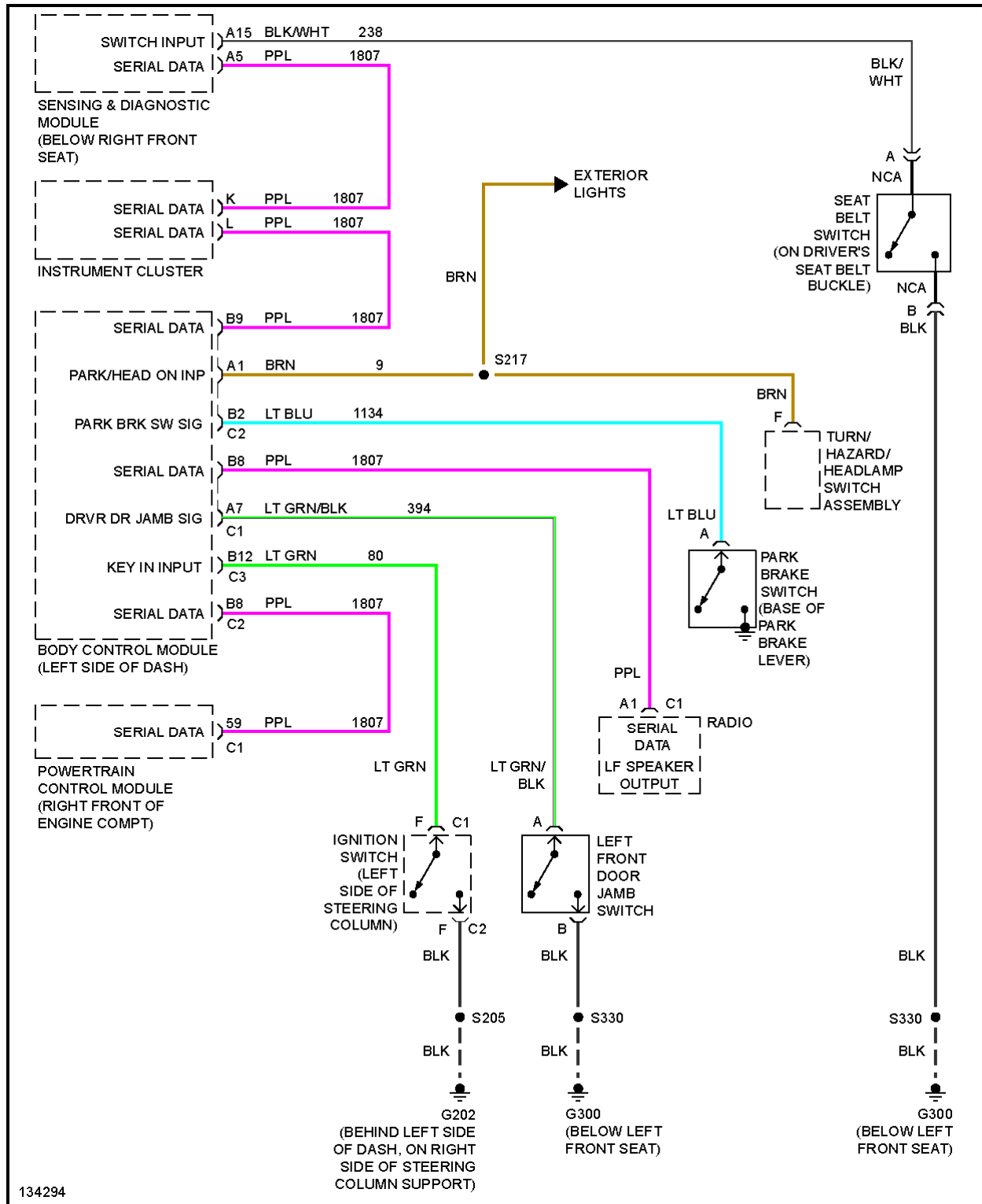

**Fig. 46: Trunk Release Circuit**

## WARNING SYSTEMS

# 2000 Pontiac Sunfire SE

## 2000 System Wiring Diagrams 'Pontiac - Sunfire

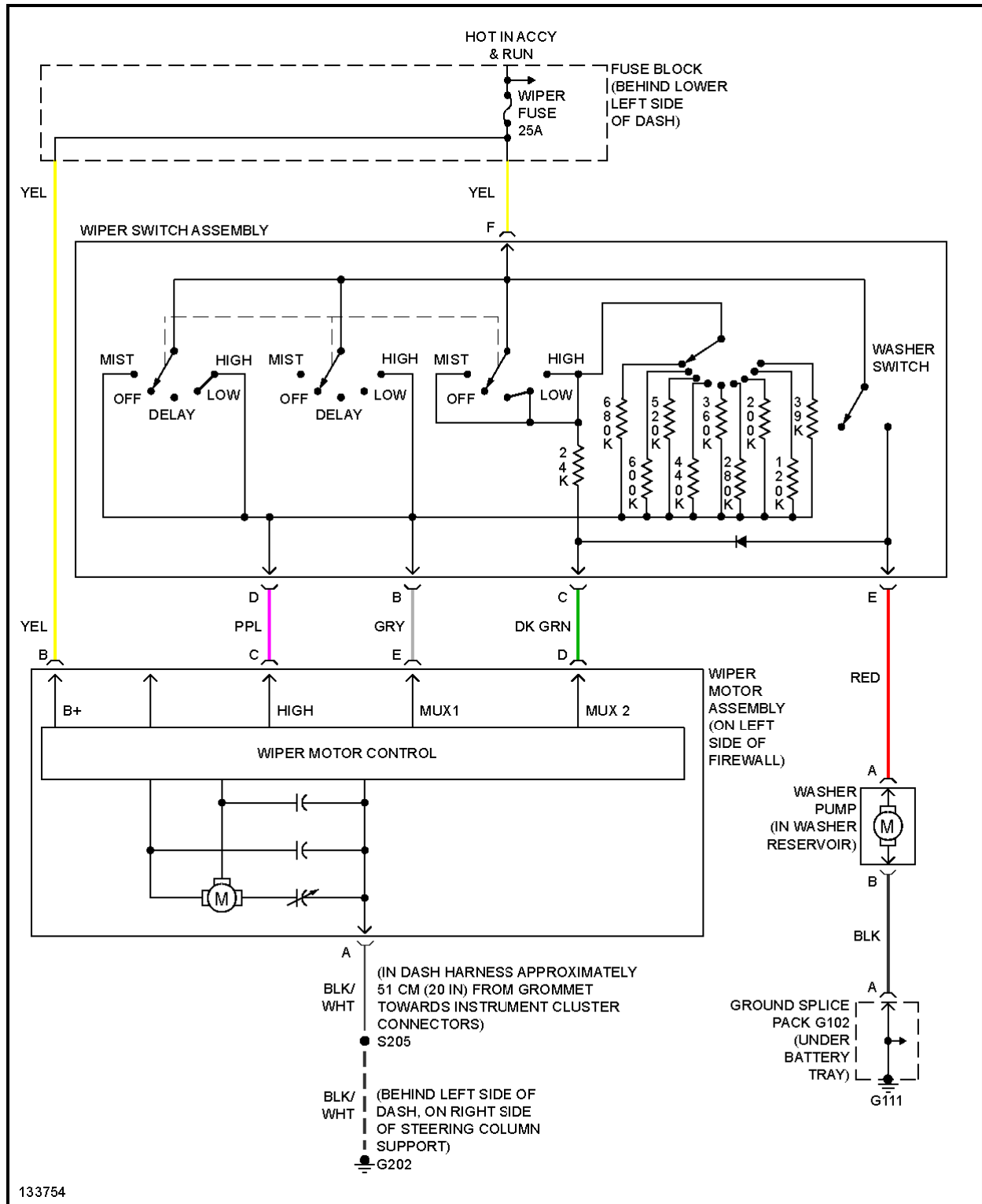

**Fig. 47: Warning System Circuits**

**WIPER/WASHER**

# 2000 Pontiac Sunfire SE

## 2000 System Wiring Diagrams 'Pontiac - Sunfire

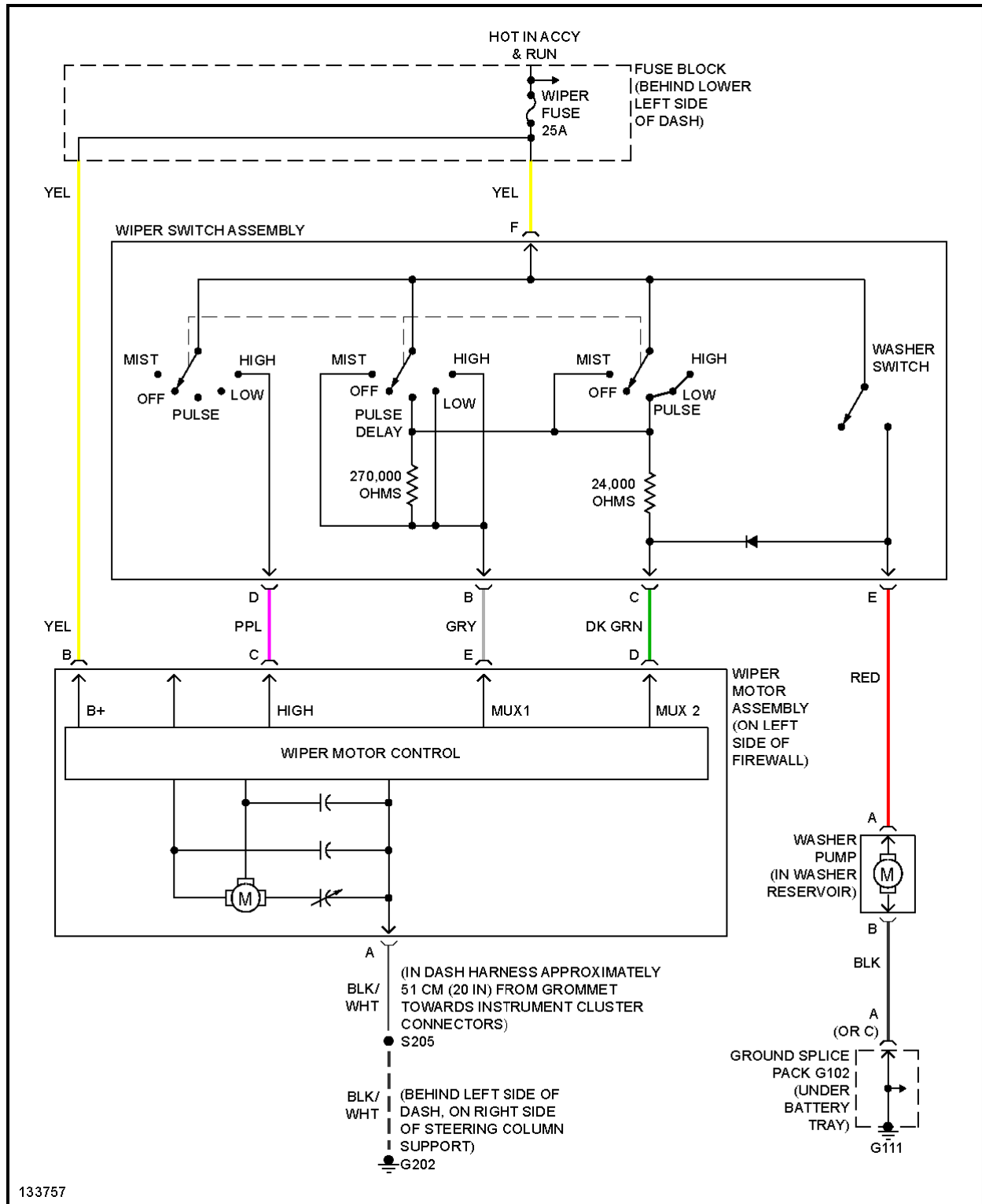



**Fig. 48: Intermittent Wiper/Washer Circuit**

# 2000 Pontiac Sunfire SE

## 2000 System Wiring Diagrams 'Pontiac - Sunfire



**Fig. 49: Pulse Wiper/Washer Circuit**